

# Industrial Experience with State-Space Model Predictive Control

Ernest F. Vogel and James J. Downs  
Eastman Chemical Company  
Kingsport, Tennessee

## Abstract

Experience with infinite-horizon state-space model predictive control confirms that the algorithm offers several advantages over the more conventional finite-horizon step-response based model predictive control algorithms, particularly in the specification of sample time and handling a wide range of process time constants. Examples illustrate our use of state space based model predictive control and its integration with conventional control techniques.

## Keywords

Model predictive control, State space, Application, Constraint control, Multivariable control strategy

## Introduction

The Advanced Controls Technology Group at Eastman Chemical Company has nine years of experience applying predictive control on industrial processes. The first five of those years, we applied our own variation of Dynamic Matrix Control (DMC). Our DMC is similar to the conventional finite-horizon, step-response-model based predictive control technology commonly applied in the chemical process industries (Cutler and Ramaker, 1980; Richalet et al., 1978). Four years ago, we began applying infinite-horizon state-space model predictive control, denoted here as MPC. We now have 35 installations of this technology. The state space formulation offers several advantages over the convolution model approach. As a result, all of our new applications use MPC. The DMC applications are still in service and, so far, we have not converted any of them to MPC. While the MPC algorithm offers several advantages, it still has some features which make it challenging to implement. In this paper, we briefly describe the strengths and weaknesses we have found in our experience with the MPC algorithm. We also discuss control strategy design with MPC and give two example problems.

## MPC Implementation

The state-space predictive controller implemented at Eastman follows that documented by Muske and Rawlings (1993). Our implementation uses a fixed gain Kalman filter for the observer and a quadratic program formulation to determine the steady state targets. The regulator portion of the algorithm uses input parameterization as described by Muske (1995). This technique assumes that the inputs follow a  $u = -Kx$  path from the end of the move horizon onward. The feasibility of output constraints is achieved by softening the constraints as presented by Ricker et al. (1988) and Zheng and Morari (1995). Although there can be significant performance limitations with this approach for non-minimum phase systems as discussed by Scokaert and Rawlings (1999), we have not observed the problems they discuss. The steady-state and dynamic optimization problems result-

ing from the state-space control algorithm are solved using a quadratic programming algorithm described by Powell (1985) and Schmid and Biegler (1994).

## Strengths and Weaknesses of State-Space MPC

### Process Dynamics

One of the strengths of state-space MPC is the relative independence of controller sample time and process time constants. Because the algorithm does not use a step-response model, the sample time can be very small relative to the process time constants. Also, the range of process time constants can be very wide. This capability is important when the MPC strategy includes variables that can respond quickly, such as distillation column differential pressure, and variables that can respond much more slowly, such as column product composition. The variables that respond quickly require a short sample time. The ability to have small sample times relative to process time constants makes state-space MPC applicable on a broader range of problems and provides more flexibility in its implementation, compared to step-response based algorithms. Additionally, the sample time is much easier to select with state-space MPC, because of the independence from the process time constants.

Dead time can still present a problem for state-space MPC. Because every sample time of dead time creates an additional state, small sample times relative to the dead time lead to a large number of states. While we have not encountered any implementation problems associated with the number of dead time states, our experience in this area is limited. So far, our largest number of dead time states for a single input/output pair has been 11.

### Tuning

The state-space MPC algorithm has three major parts: the state observer, the steady-state target calculation, and the dynamic regulator. The calculations for each of these parts are performed each control interval. Each

of these parts must be tuned for the specific application. The final steady-state is affected only by the steady-state tuning. The dynamic performance of the controller is affected by the tuning of both the state observer and the regulator.

The separation of the steady-state performance and the dynamic performance within state-space MPC is a good feature. The steady-state weighting/tuning parameters have proven relatively easy to set to achieve the desired final steady-state. However, the dynamic weighting/tuning parameters in both the state observer and the regulator are more difficult to set to achieve the desired dynamic response. Further, the dynamic response can be adjusted by changing parameters in either the state observer or in the dynamic regulator. The best method for dynamic tuning is not fully clear.

State-space MPC offers the option of modeling disturbances on either the process input or output. Our algorithm includes both options. We have experimented with each option on some applications, but the best choice for that decision is seldom clear. We normally assume unmeasured disturbances enter at the process input unless process understanding dictates otherwise. Our applications have not required the identification of disturbance models other than the common step disturbance. In a proportional-integral controller sense, we view the regulator as providing the proportional part and the observer providing the integral mode. Unmeasured disturbances are picked up by the observer via the disturbance model and require reset action. Tuning of the disturbance model has become similar to tuning resets on conventional controllers.

State-space MPC has many tuning parameters. They require adjustment based on observed performance. For most problems, our experience has been that MPC tuning needs to be done off-line with a simulation.

## Control Strategy Design

While the previous section discussed aspects of the state-space MPC algorithm itself, we have found that the control strategy design with MPC has a far bigger impact on the success of a project than the performance of the MPC algorithm itself. By control strategy design, we mean definition of the control objectives, selection of control technology (MPC or traditional SISO structures), and the selection of controlled, manipulated, and constraint variables for MPC.

To illustrate our use of MPC, two examples are given below. A common control problem at Eastman is the distribution of load between parallel unit operations. The ability to handle non-square systems makes model predictive controllers an attractive control technology for this problem. In the first example, the capability to characterize the process control objective and to prioritize competing objectives is illustrated along with the capa-

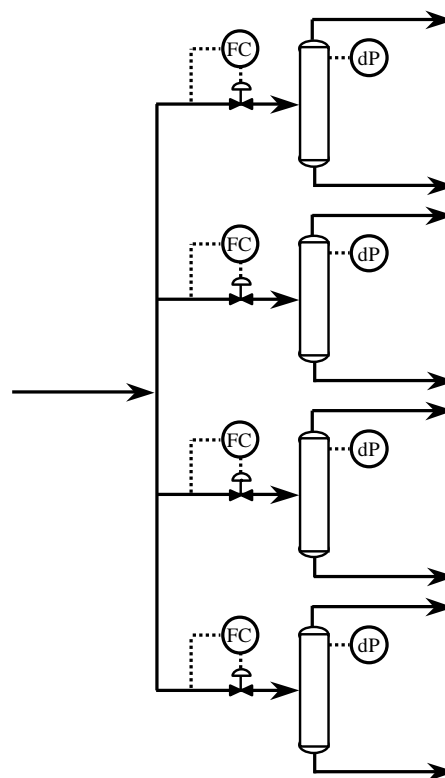

Figure 1: Distillation columns in parallel.

bility to specify widely different closed-loop time constants within the same controller. In the second example, the capability to cascade multiple MPC layers and to integrate MPC with conventional control is shown to further enhance the strength of this technology.

### Example 1—Distillation Columns in Parallel

Figure 1 shows four distillation columns in parallel service. The columns already have an excellent regulatory SISO strategy in place to control top and bottom compositions. The control problem is to distribute the total throughput subject to the hydraulic limits of the columns as indicated by their maximum differential pressures. Therefore, this problem has one controlled variable (total throughput), four manipulated variables (column feed rate set points), and four constraint variables (column differential pressures).

The control strategy objectives are summarized below in order of priority with the first item being the most important.

Objective	Speed
1. Satisfy manipulated variable constraints (hard constraints).	Instantaneous
2. Satisfy differential pressure constraints (soft constraints).	Fast
3. Satisfy total throughput target or maximize total throughput subject to constraints.	Slow
4. Distribute feed so all columns are equally loaded as measured by the distance from their differential pressure constraints.	Very slow

The specification of the control objectives is a major step in an advanced control application and typically goes through several iterations. Often, the best way to operate the equipment is discovered through experimentation with different objectives. In this case, the objectives are given above and the next step is to decide on the control technology and configuration required to meet the objectives. There are several possibilities including an exclusively SISO strategy, an exclusively MPC strategy, or a hybrid. The best choice depends not only on which technology will best meet the objectives, but also on several other factors: the size of the MPC problem (number of controlled and manipulated variables), maintenance of the algorithm, maintenance schedules for the physical units, reliability of the measurement and communication links, and understandability.

For this particular application, we chose to use MPC, but with four additional controlled variables. In order to distribute the feed so all columns are an equal distance from their differential pressure constraints, we included for each column the difference between the high differential pressure limit and the current differential pressure. Those four controlled variables have a set point of zero. With a high steady-state weight in state-space MPC, we specify that the total throughput should be at set point. The four “constraint distance” controlled variables have a low steady-state weight. Since there are five controlled variables and four manipulated variables, all the set points cannot be reached. The total throughput goes to its set point and state-space MPC distributes the set point error equally for the four constraint distance variables.

The four column differential pressures are still needed as high constraint variables in MPC for speed of response reasons. The tuning is such that the distribution of the feed happens very slowly, but if something happens which drives a differential pressure to the constraint, the associated feed rate is moved quickly to compensate.

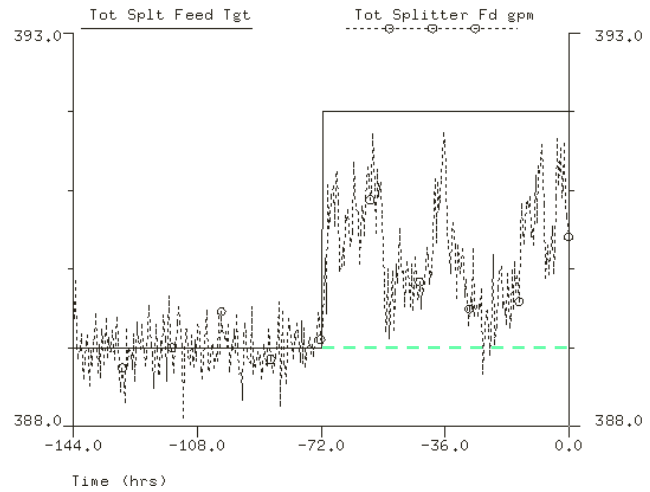

Figure 2: Total production rate for distillation columns in parallel.

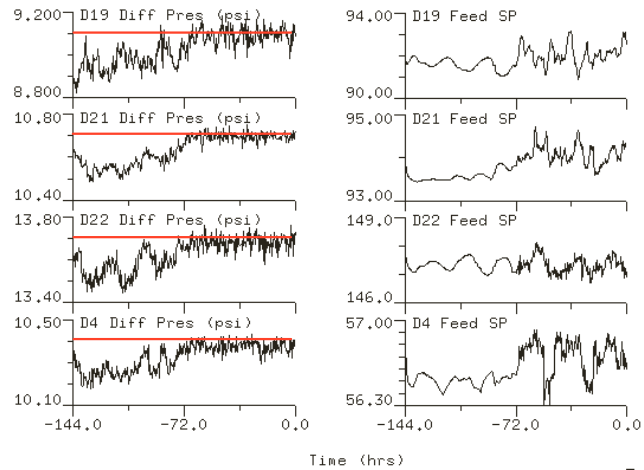

Figure 3: Differential pressures and feed rates for distillation columns in parallel.

Figures 2 and 3 demonstrate the response for a production rate target increase beyond what is achievable. Figure 2 shows that prior to the change, the total rate is at target. After the target change, the total flow does not reach the target, but is maximized subject to the constraints. Figure 3 shows the column differential pressures all at approximately the same distance from the high limit prior to the target change. After the target change, the differential pressures are running at the high limits. Also, note that prior to the target change, the

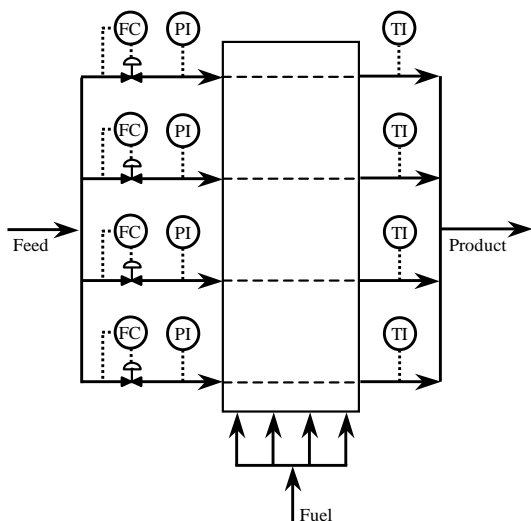

Figure 4: Cracking furnace.

column feed rates move relatively slowly. However, the column feed rates move more aggressively after the target change when the columns are running on their differential pressure constraints.

**Example 2—Cracking Furnaces in Parallel**

A process gas is cracked in a natural gas fired furnace. Figure 4 shows a process diagram of a furnace. The process gas flows through four separate coils in the furnace. Each coil has its own inlet feed flow controller, inlet pressure measurement (downstream of the feed valve), and outlet temperature measurement. The combustion air flow is ratioed to the natural gas flow. There are 5 manipulated variables for controlling the furnace: each of the 4 inlet feed flow controller set points and the fuel flow controller set point.

The furnace production rate (sum of all 4 coil flows) is set by product demand (sometimes to be maximized). Coil outlet temperature is indicative of conversion and needs to be controlled on each coil. Coil inlet pressure can float but must not exceed a high limit because excessive coil inlet pressure causes a relief valve to open. The maximum fuel rate limit is determined by the furnace emission permit.

Changing a coil flow not only affects its own outlet temperature, but it also affects the outlet temperatures of the other 3 coils as well. As a result, most process changes or disturbances require adjustment to all 5 manipulated variables. Thus, it is a true multivariable control problem.

MPC is an excellent control technology for this problem because it is multivariable and because of the process constraints. For this application we used state-space

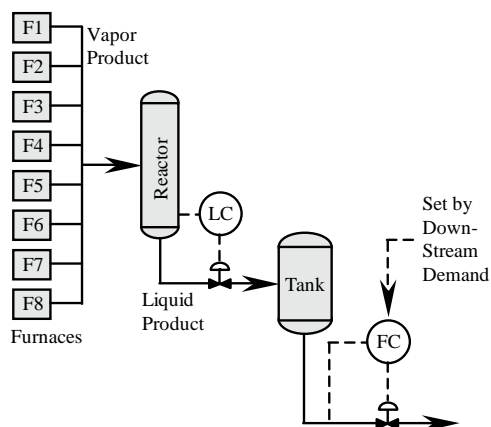

Figure 5: Cracking furnaces in parallel.

MPC with 5 controlled variables (total rate and 4 outlet temperatures), 5 manipulated variables (fuel flow and 4 inlet feeds), and 4 constraint variables (4 coil inlet pressures).

In our application, there are 8 of these furnaces in parallel supplying a common user. Figure 5 shows a diagram of the system. The control objectives for this system are very similar to those for the distillation column system and are summarized below in order of priority with the first item being the most important.

Objective	Speed
1. Satisfy manipulated variable constraints (hard constraints).	Instantaneous
2. Satisfy coil inlet pressure constraints (soft constraints).	Fast
3. Control coil outlet temperatures at their target.	Medium
4. If a furnace becomes constrained or if a furnace is shut down or started up, redistribute load to maintain total rate.	Medium
5. Control the downstream inventory at target or maximize throughput subject to constraints.	Slow
6. Distribute feed so all furnaces are at equal total rate to maximize run length.	Very slow

Again, MPC is attractive for this load distribution application. However, it is a significantly bigger problem

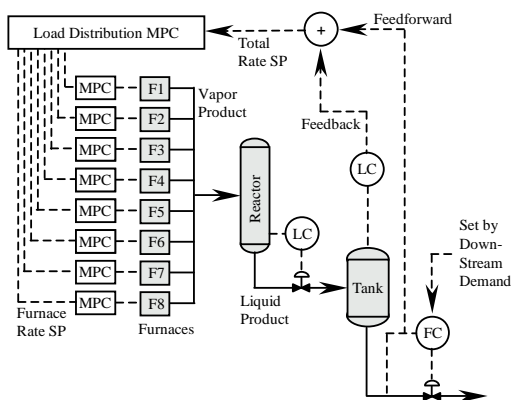

**Figure 6:** MPC control strategy for cracking furnaces in parallel.

than the distillation example above: 33 controlled variables (1 level, 32 temperatures), 40 manipulated variables (32 process feeds, 8 fuel rates), and 32 constraint variables (32 coil inlet pressures). Because of the size of the problem, several MPC control strategy options should be considered. One option is to do this problem with one big MPC. A second option is to control each furnace with an MPC and layer a master load distribution MPC on top of the 8 slave MPCs.

The solution we implemented is a variation of the latter choice and is shown in Figure 6. We chose this configuration for several reasons:

1. The top MPC layer can easily be turned off and furnace MPCs operated individually.
2. A PID controller was used for level controller because it was easier to tune and it met the need.
3. The smaller MPCs are less of a computational load.
4. The system could be built in steps. Successive furnace MPCs could be built and brought on-line without disturbing ones commissioned earlier.
5. The system is easier to maintain. Any code/configuration maintenance can be done while a furnace is down without disturbing running furnaces.

Except for very small problems, such as the distillation example, we normally choose to layer a master MPC on top of slave MPCs that manage parallel unit operations.

## Conclusions

While state-space MPC offers several advantages over step response based algorithms, implementation still requires a great deal of expertise simply to use and tune the algorithm. The control strategy design when incorporating MPC has a far bigger impact on success of a project

than the performance of the MPC algorithm itself. The examples illustrated the flexibility of state-space MPC to achieve a variety of control objectives, both in importance and speed of response. The state-space MPC technology has become an important tool for Eastman Chemical Company when solving control problems that have complex control objectives and widely different time frames.

## References

- Cutler, C. R. and B. L. Ramaker, Dynamic Matrix Control—A Computer Control Algorithm, In *Proceedings of the Joint Automatic Control Conference* (1980).
- Muske, K. R. and J. B. Rawlings, “Model Predictive Control with Linear Models,” *AIChE J.*, **39**(2), 262–287 (1993).
- Muske, K. R., *Linear Model Predictive Control of Chemical Processes*, PhD thesis, The University of Texas at Austin (1995).
- Powell, M. J. D., “On the quadratic programming algorithm of Goldfarb and Idnani,” *Math. Prog. Study*, **25**, 46 (1985).
- Richalet, J., A. Rault, J. L. Testud, and J. Papon, “Model Predictive Heuristic Control: Applications to Industrial Processes,” *Automatica*, **14**, 413–428 (1978).
- Ricker, N. L., T. Subrahmanian, and T. Sim, Case Studies of Model-Predictive Control in Pulp and Paper Production, In McAvoy, T. J., Y. Arkun, and E. Zafiriou, editors, *Proceedings of the 1988 IFAC Workshop on Model Based Process Control*, pages 13–22, Oxford. Pergamon Press (1988).
- Schmid, C. and L. T. Biegler, “Quadratic programming methods for reduced hessian SQP,” *Comput. Chem. Eng.*, **18**, 817 (1994).
- Scoekaert, P. O. M. and J. B. Rawlings, “Feasibility Issues in Linear Model Predictive Control,” *AIChE J.*, **45**(8), 1649–1659 (1999).
- Zheng, A. and M. Morari, “Stability of Model Predictive Control with Mixed Constraints,” *IEEE Trans. Auto. Cont.*, **40**(10), 1818–1823 (1995).