

## POSCO YARD CRANE AUTOMATION

Sangchul Won\*, Sang-un Kim\*, Seung-Gap Choi\*\*  
and Chintae Choi\*\*\*

\* *Department of Electrical Engineering, Pohang University  
of Science and Technology, Pohang, Korea*

\*\* *Technical Research Laboratory, POSCO, Pohang, Korea*

\*\*\* *Department of Mechanical and Electrical Engineering,  
RIST, Pohang, Korea*

Abstract: This paper describes an integrated approach for crane automation at the Kwangyang steel works, POSCO. Unmanned cranes are composed of several technologies, which include anti-sway control, precision position control, optimal trajectory computation, and coil shape recognition. Crane position while traveling and the traverse axis are controlled by PID position controllers. In order to prevent swaying during crane operation, the sway angle is consistently suppressed from the start point to the destination using an anti-sway algorithm. For optimal trajectory control, 3-axis motion was analyzed and variable speed drives were used. A 3D object recognition system for picking up coils, based on stereo vision, is in progress. Some of the described control strategies have been successfully applied to the 10-1 crane in the No. 4 CGL (Continuous Galvanizing Line) of the Kwangyang steel works, POSCO. Substantial cost reduction and improved productivity are expected benefits of crane yard automation. *Copyright*©2005 *IFAC*

Keywords: Crane automation, Position control, Anti-sway control, Recognition

### 1. INTRODUCTION

Cranes compose a diverse group of machines that not only lift heavy objects but also shift them horizontally. Cranes have come into their present widespread application since the introduction of steam engines, internal-combustion engines, and electric motors, beginning in the 19th century.

In an effort to improve the efficiency of the overall operation of plants, POSCO, a major Korean steel producer, recognized the following problems in the coil yard operation which required immediate attention: high labor cost - approximately 500 crane operators were on staff in the coil yard, high maintenance costs - unskilled substitute operators damaged cranes by rough usage during frequent crane operator strikes. In order to solve the prob-

lem POSCO's top management considered the full automation of existing yard cranes.

For decades much research has focused on overhead cranes automation, but only a few successful results has been reported. Integrated crane control systems designed by well known engineering companies are still expensive and are not satisfactory in the view of maintenance and reliability. To this end, a more appropriate control system fit to requirements of various cranes at POSCO was designed and applied to a rolling plant which has been successfully operated for 1 year. The new system has better rope anti-sway and position control capabilities.

POSCO is currently, undertaking automation of

coil yards at the hot rolling plants and cold rolling plants at Kwangyang, using newly developed technologies. Up to now, 4 cranes have been automated, while the remainder are awaiting upgrades during the next regular maintenance period.

The project scope includes mechanical refurbishment and complete electrical retrofits of each crane, as well as the addition of a new coil tracking and inventory system. The crane retrofits include conversion variable speed AC drives, PLC controllers and wireless network communication systems. Each crane was also equipped with laser-based distance meters for actual absolute position measurement.

Positions of the traveling and traverse axes are controlled by PID position controllers. The controller was designed in the continuous time domain by using a loop-shaping method which was then converted to a discrete form for computer code generation by z-transform. Coil-handling cranes have long rope and short sheave distances, and therefore rope sway occurs easily. A long sway period introduced by the long rope makes long sway decay time and un-manned operation difficult. Sway of the rope is suppressed by an anti-sway control algorithm. The sway angle of the rope is measured by a sway angle sensor which mechanically touches the rope and is consistently suppressed from the start point to the destination by PD control law. The control frequency of the overall controller, which is comprised of the position and the anti-sway controller, is 25Hz on account of the dynamics of moving axes. Some algorithms required for coil yard operations, which also main control algorithms, such as reference position generation, position control and anti-sway control, have been designed and fully tested on the new crane simulator. The newly designed crane control system has shown satisfactory performance on position control accuracy and the anti-sway of rope. The maximum positional error is 30mm and the maximum sway error is 0.1 degrees.

A skilled human operator has intimate knowledge of the process at hand, and performs given jobs most efficiently to meet various operational goals under various circumstances. Therefore, the automated system should also perform given jobs in minimum time for productivity. For this reason, special attention has been given to the optimization of the crane movement required to carry out each type of work instruction, to facilitate short crane cycle time. Simultaneous movements on traveling, traverse and hoist axes have been realized over the collision-free height to reduce cycle time. The proposed control strategies have been successfully applied to the 10-1 crane in

the No. 4 CGL of at POSCO's Kwangyang Steel Works.

## 2. OUTLINE OF UNMANNED CRANE

Prior to this project, cranes were operated manually. The crane job supervisor accessed the Level 3 yard planning system through a terminal computer at the central pulpit, and work instructions for crane movements were transferred between the supervisors in the pulpit and the crane operators via telecommunication. The new automated crane system performs the above job by itself, without a human supervisor. The major features of the new automation system include:

- Unmanned Crane Operation - Each crane executes work instructions, which are generated either automatically by the Level 3 enterprise system or manually by the operator in the central pulpit.
- Remote Crane Operation - In order to prepare exceptional work conditions, any motion for a selected crane can be made directly by the operator from any of two remote operation stations located in the central pulpit.
- Automatic Slab Tracking - All slab movements are traced and stored in a central database.
- Variable Speed Drives - Improved crane performance and control, and a reduction in mechanical damage.
- Precise Position Control - Feedback-based position control achieves precise positioning at the goal position and reduces surface damage of a coil when it is placed on the skid.
- Anti-Sway Control - Consistent suppression of rope sway by feedback control during crane movement fully satisfies sway bound at the goal position.
- Integrated Crane and Conveyor Control - Conveyor motion is interlocked with crane motion to enhance safety and reduce equipment damage.
- Modern Diagnostic System - Based on the latest Human Machine Interface (HMI) technology.
- Coil shape recognition system - Based on stereo vision technology and an object recognition algorithm.

The crane system consists of the main control computer in the pulpit and a Programmable Logic Controller(PLC) on the crane. The data communication between the main control computer at ground and the programmable logic controller is done by wireless LAN. Figure 1 shows the overview of the unmanned crane. The main control computer sends coil move commands and receives crane status information. The PLC gen-

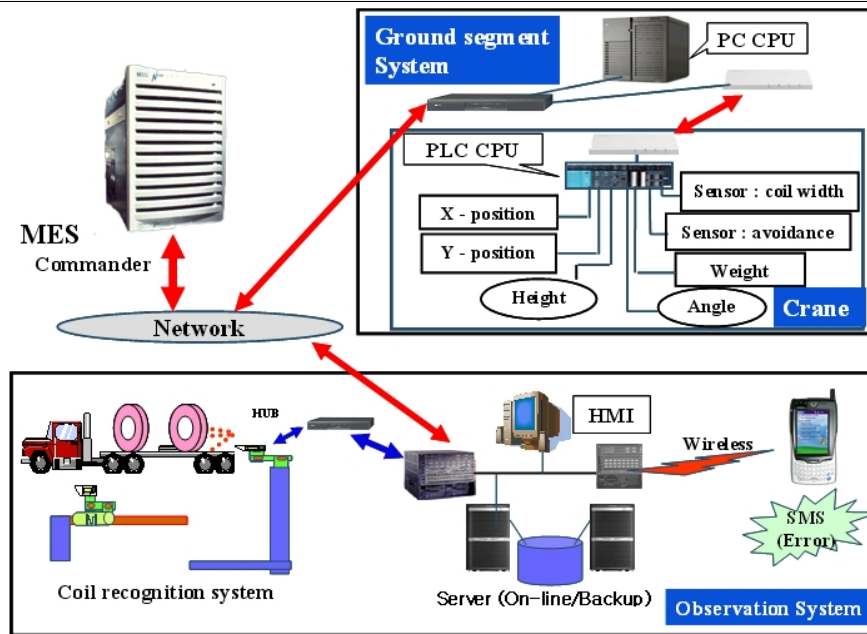

Fig. 1. Overview of the unmanned crane.

erates moving trajectories and performs real-time control of crane positions and rope sways, and reports crane status to the main control computer. The main control computer determines which coil to move and positions to pick up and place the coil. Whenever a coil transfer command is generated, the computer sends coil transfer position data and data related to the coil itself, such as outer diameter, width, weight and so on. This crane control system allows operators to interfere automated process and can pause and resume crane movement at any time during operations.

Figure 2 shows the location of sensors for position and velocity control, anti-sway and crane safety.

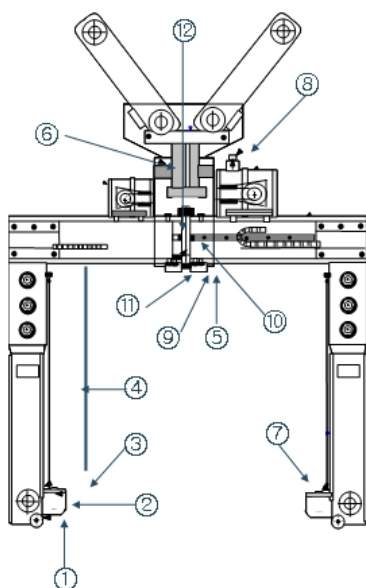

Fig. 2. Sensor locations.

- (1) Obstacle sensor - to detect obstacles under the crane during lift down
- (2) Coil hole sensor - to determine whether shoes are correctly positioned at the center of the coil hole
- (3) Lifter load sensor - to determine whether coils are lifted off normally
- (4) Coil tactile sensor - to determine whether the lifter arm grips the coil properly
- (5) Lifter rotation sensor - to detect rotation of the lifter (90, 180, 270 degrees)
- (6) Rotation angle sensor - to measure the rotation angle of the lifter (for acceleration and deceleration)
- (7) Shoe In/Out sensor - to determine whether shoes are in or out
- (8) Rotation limit switch - to detect the limit of lifter rotation
- (9) Lifter arm sensor - to detect the opening of the lifter arm
- (10) Lifter arm limit switch - to determine the maximum and minimum of lifter arm opening
- (11) Coil top sensor - to determine whether the coil is positioned correctly right under the lifter
- (12) Coil center sensor - to determine whether the lifter is at the center of the coil.

### 3. AUTOMATION TECHNOLOGIES

Figure 3 shows a flow chart of the unmanned crane process. A new control algorithm was developed and applied to the position control, trajectory generator and coil shape recognition of the system. The control algorithm is composed of 4 parts;

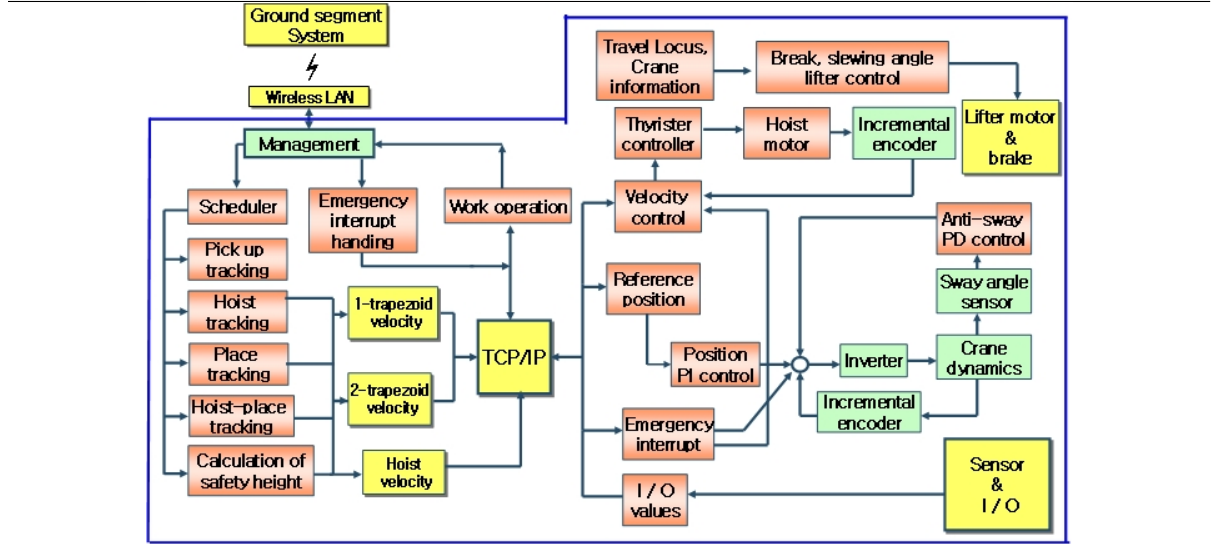

Fig. 3. Flow chart of unmanned crane process.

1) position and anti-sway controllers, 2) velocity constraints attendant on the working area, 3) a simultaneous 3-axis motion process, and 4) a coil shape recognition system.

### 3.1 Design of Position and Anti-sway Controllers

Figure 4 shows an overall block diagram of the position and anti-sway control system. It is assumed that the transfer functions of the dynamic model of position control system on the traveling and traversing axes are 2nd-order systems. The transfer function on the traveling axis are modelled as follows:

$$G_m(s) = \frac{0.24}{s(0.5s + 1)} \quad (1)$$

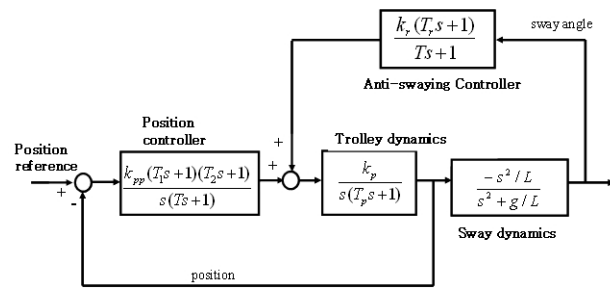

Fig. 4. Overall block diagram of position and anti-sway control.

The open-loop Bode plot for  $G(s)$  is shown in Fig. 5. The roll-off rate at the cross-over frequency is -20 dB/dec. But if a large proportional gain is used in the feedback controller, the loop shape goes up, and the roll-off rate in the cross-over frequency will be -40 dB/dec. Positions of the traveling and traverse axes are controlled by PID position controllers. The controller was designed in the continuous time domain using a loop-shaping method and converted to the discrete form for computer

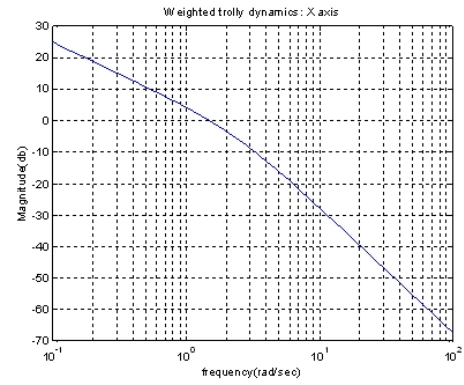

Fig. 5. Bode plot of the trolley dynamics (weighted open loop).

code generation by z-transform. So insertion of two finite zeros near the cross-over frequency and an integrator guarantees that the target loop will have -20 dB/dec. The shaped plant is obtained by inserting a loop compensator, where -0.4 and -0.5 are assigned to  $T_1$  and  $T_2$ , respectively. Another pole is introduced to satisfy properness of the transfer function. The  $k_p$  was set at 100 to the position error sufficiently attenuate. A feedback control system with a designed compensator gave a good transient response. It also showed that the higher roll-off rate in the higher-frequency region gives robustness to measurement noise.

As shown in Fig. 4 the transfer function of sway dynamics  $G_s(s)$  where the input is a trolley position and the output is sway angle, has two undamped poles and two zeros at the origin.

$$\frac{\Theta(s)}{X(s)} = G_s(s) = \frac{-s^2}{ls^2 + g} \quad (2)$$

The zeros near the origin dominate plant dynamics and undamped poles make rope sway decay very difficult. Rope sways in the traveling direc-

tion and the traverse direction is suppressed by PD control laws. The position controller and the

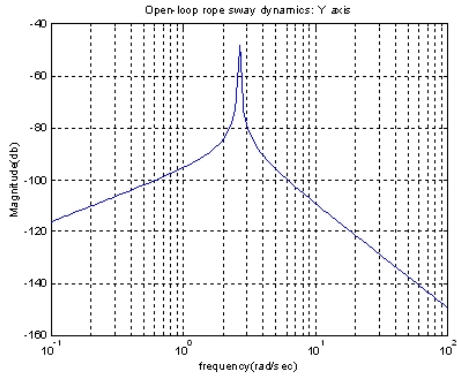

Fig. 6. Bode plot of the sway dynamics.

anti-sway controller designed in the continuous domain is transformed to a discrete-time domain controller through bilinear transformation. The algorithm was written in PASCAL language for actual control in PLC, and executed every 0.04 sec.

### 3.2 3-axis simultaneous motion of the crane

Typical functions of the POSCO yard crane consist of a sequence of motions such as vertical hoisting, traversing, traveling, traversing and vertical dropping. Skilled crane operators perform two motions at the same time to reduce the cycle time. However the speed of each motion depends on the level of skill. The new crane control system generates an optimal trajectory in the safety zone for each job and performs 3-axis motions simultaneously to minimize cycle times. The safety yard height ( $h_1$ ) is set by considering the height of the largest coil or instruments and the safety coil height ( $h_2$ ) is set by computing the half outer radius of coil carried by lifter. Then the safety zone height ( $h_3$ ) where crane travels, the traverse is set at  $h_3 = h_1 + h_2$ . The start-winding distance ( $d$ ) is 500mm from the traveling axis, and 300mm from the traverse axis.

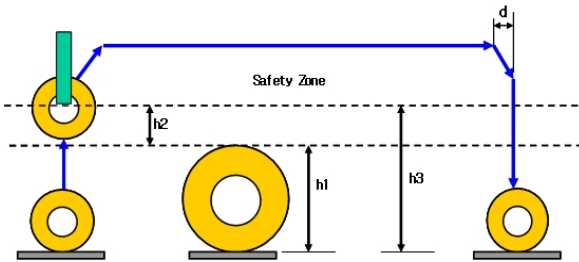

Fig. 7. 3-axis linked movement process.

### 3.3 Working area velocity constraints

The crane control system divided the working area of the POSCO yard into two categories. One is "normal area" or "unsafe area" where only coils are stored and the other is the unsafe area where trucks or workers move around. Figure 8 shows the working area of the 4 CGL yard. Depending on the area, the control system generates a crane trajectory which reduces speed when the crane moves into crowded unsafe areas. Typical high speed in a normal area is 108mpm, and the average low speed in a unsafe area is 36mpm.

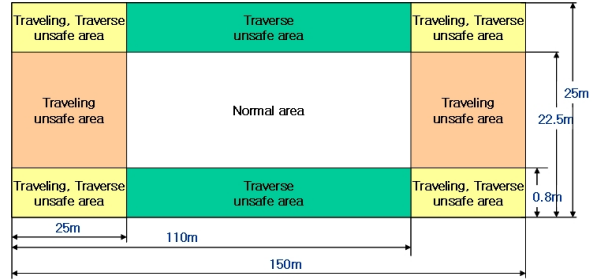

Fig. 8. Working area of the 4 CGL yard.

### 3.4 Coil shape recognition system

Image based vision processing is effective in recognizing important geometric features of an object and leads to accurate estimation of the object's position/orientation required for pickup operations by a crane. In order to recognize the coil shape and to compute the position and orientation of the coil, a 3D disparity map was established using stereo images. The 3D vision system is implemented on FPGA chips generating disparity values from stereo camera images at high speed. The system can measure the 3D features of a coil such as position, orientation, width and radius for unmanned cranes. This system consists of fast stereo vision and a 3D object recognition algorithm. The fast stereo vision system accepts the left and right images from the stereo cameras and generates disparity images. A disparity image can be converted into the range image that contains 3D information. The 3D object recognition algorithm is based on 3D planar surface extraction by segment based stereo vision using range images and cylinder fitting technique.

Stereo vision as shown in Fig. 9 builds a 3D description of a scene observed from two or more viewpoints. Once disparity values between two images are found, depth was obtained using the triangulation principle. The disparity is the difference between the corresponding points on both stereo images, which are two projected points of the same world point on both cameras. For fast

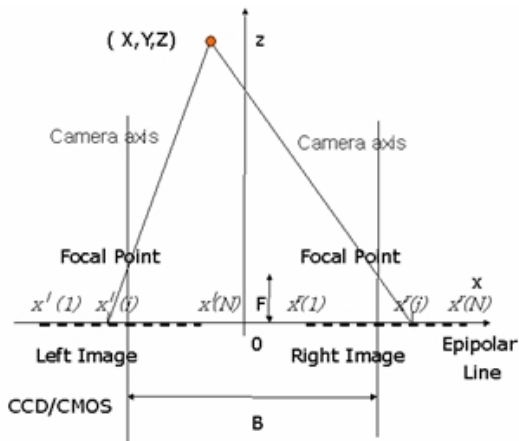

Fig. 9. Stereo vision geometry.

processing, a trellis-based stereo matching method is implemented on a FPGA chip. Since the stereo matching algorithm has a systolic array structure, it is well suited to parallel processing and is easy to be implemented. Moreover, this scheme enables connection of several chips for increased performance. The current system uses two FPGA chips and handles two stereo  $1300 \times 640$  images to generate the disparity image. The two FPGA chips have processed a pair of  $1300 \times 640$  images at 30 frames per second. However, the real speed of the vision system is about 7 frames per second due to PCI bus band-width limit. Fig. 10 and Fig. 11 shows each camera image and the disparity image.



Fig. 10. Stereo image in steel coil yard.

#### 4. CONCLUSION

This paper presented the POSCO unmanned crane project. The new crane control system is composed of several technologies, which include anti-sway control, precision position control, optimal trajectory computation, and coil shape recognition. The newly developed crane control system



Fig. 11. Disparity image generated from stereo images.

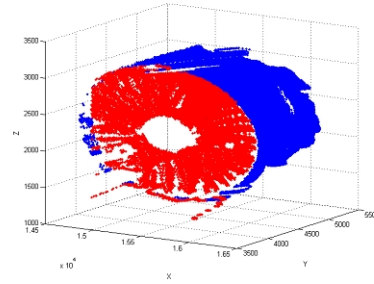

Fig. 12. Segmented surfaces and recognized object.

has been applied at the Kwangyang steel works, POSCO. The unmanned crane has been operated for 24 hours a day. Moreover, several remote-controlled cranes have been operated successfully by only one operator. Through crane automation, labor costs have been substantially reduced and productivity has been increased.

#### REFERENCES

- Miyata, N. et al.(2000). Auto-Steering System for Transfer Crane. *Mitsubishi Juko Giho* Vol.38, No.2, pp. 67–72.
- A.Piazzini, A.Visioli.(2002). Optimal dynamic-inversion-based control of an overhead crane. *IEE Proceedings of the Control Theory and Applications* Vol.149, No.2, pp. 405–411.
- E.Arnold, O.Sawodny, A.Hildebrandt (2003). Anti-sway system for boom cranes based on an optimal control approach. *Proceedings of the American Control Conference*. Vol.4, pp. 3166–3171.
- Obata, Koji Uchida, Takashi Chikura, Yoshikawa, Monzen (2003) Automated transfer Crane. *Mitsubishi Heavy Industries, Ltd. Technical Review*. Vol.40, No.2.
- Hong Jeong and Yuns Oh (2000). Fast stereo matching using constraints in discrete space. *IEICE Trans. On Information and Systems*. vol.E83-D, No 7, pp. 1592–1600
- Sungjin Kim, Seungjun Choi, Sangchul Won and Hong Jeong (2004). The coil recognition system for an unmanned crane using stereo vision. *IECON'04*.