

Can stormwater physico-chemical treatment improve global WWTP performance?

A. Bouarab^{*,**}, I. Baudin-Bizien^{**}
X. France^{***}, O. Potier^{*}, M.N. Pons^{*}

^{*}Laboratoire Réactions et Génie des Procédés (UMR CNRS 7274), Université de Lorraine, Nancy, France
(email: amine.bouarab@univ-lorraine.fr; olivier.potier@univ-lorraine.fr; marie-noelle.pons@univ-lorraine.fr)

^{**}Veolia Environnement Recherche & Innovation,
10, rue Jacques Daguerre 92500 Rueil-Malmaison, France (e-mail: isabelle.baudin-bizien@veolia.com).

^{***}GEMCEA, 149, rue Gabriel Péri, 54500 Vandoeuvre-les-Nancy
(e-mail: Xavier.France@gemcea.u-nancy.fr)

Abstract: The efficiency of an in-line stormwater physico-chemical treatment system combining sand removal, flocculation-coagulation and subsequent settling has been assessed by simulation. Such a system is designed to both reduce the discharge of pollution during storm events in receiving water bodies and to avoid disturbances on the downstream wastewater treatment plant. The stormwater treatment model, based on an existing system, is combined to the Benchmark Simulation Model 2 wastewater treatment plant. It is demonstrated that such a stormwater treatment system can improve the wastewater treatment plant performance by reducing the violations of the effluent quality constraints, but that such improvement is mostly due to a hydraulic effect.

1. INTRODUCTION

The EU Water Framework Directive (Directive 2000/60/EC) has set regulations to protect aquatic ecosystems from the discharge of pollutants. Part of this discharge is due to the stormwater run-off on impervious surfaces (streets, roofs, parking lots, sidewalks) in cities. In case of a combined sewer system, treatment of the totality of the flow in the wastewater treatment plants (WWTP) might not be possible, for fear of washout of the biomass of the biological stage, and part of the flow is usually discharged directly in the surface waters (by combined sewer overflows). Another option is to store the stormwater either on site or along the sewer network during the rain event and to re-introduce later it into the WWTP. Reduction of flows of stormwater into the sewer system by improving the infiltration capabilities is also advocated but is difficult to install in the centre of large old cities.

In such a case, in-line treatment has been proposed to limit the negative impacts of the stormwater both on the WWTP and the surface waters. Screening, to remove gross solids (US-EPA, 1999), settling and coagulation (Gurusamy Annadurai *et al.*, 2005; Trejo-Gaytan *et al.*, 2006; Jeon *et al.*, 2013) have been proposed.

Such an in-line stormwater treatment (SWT) system (total volume of 7000 m³) has been built in the Greater Nancy (350,000 inh. urban area in the North-East of France) at the outlet of a 640 ha watershed (Boudonville, 40,000 inh.) with a 50% imperviousness. Such a system is not easy to operate and to control due to the stochasticity of the rain events, with respect to their timing and their intensity.

Experimental work has therefore been combined with a simulation approach, in order to better compare the efficiency of such a system with a more classical action line: direct treatment in the WWTP of a part of the combined sewage and overflow of the rest into the river. Unfortunately there is no complete model of the Greater Nancy WWTP, which has a complex set-up. The idea therefore has been to model the stormwater treatment system and assess its effects by connecting it to the BSM2 WWTP (Nopens *et al.*, 2010).

The remaining part of the paper is divided, respectively, into the following sections : a model of the stormwater treatment system, a short overview of the BSM2 plant model, state variables interfaces, a parameter estimation and discussion of the results,.

2. STORMWATER TREATMENT SYSTEM

2.1 Layout

Figure 1 presents the flowsheet of the stormwater treatment system. Only the sand removal, the flocculation-coagulation and settling units are actually modelled.

The water intake is controlled by two valves: an on-off valve (open when the flowrate in the sewer is larger than 150 L/s and one of the three rain gauges on the watershed detects rain) and a control valve (to control the flowrate between 150 L/s and 3 m³/s). In case the flowrate in the sewer is larger than 3 m³/s, the flow above that setpoint is directed to the river without treatment (Fig. 2).

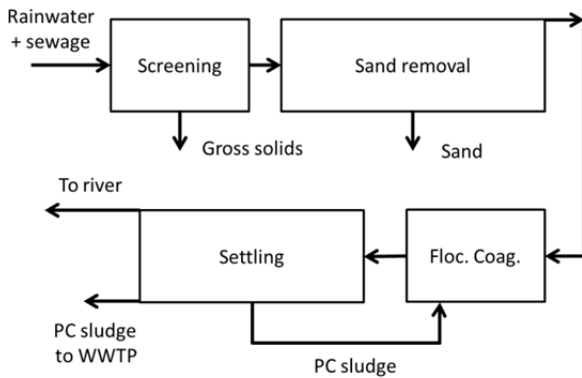

Fig. 1. SWT flowsheet

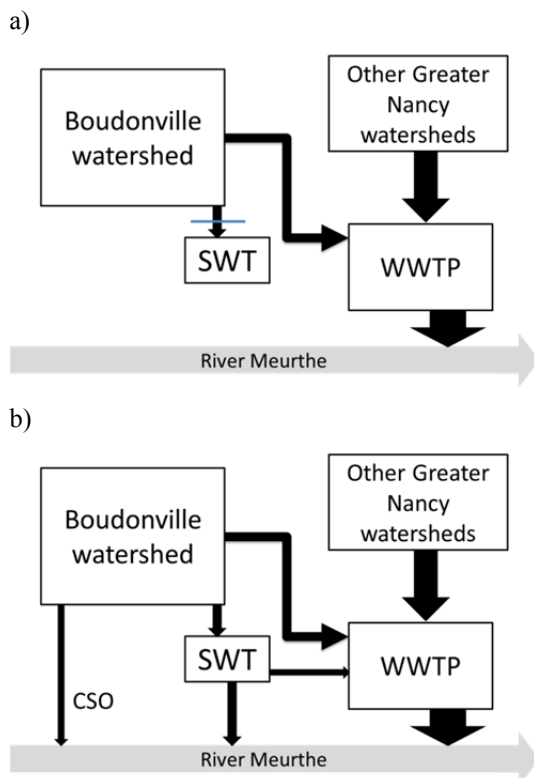

Fig. 2. Operation by dry (a) and rain (b) weather

2.2 State Variables

The definition of the state variables on which the SWT model is based is directly related to the function of the different units:

- sand (X_{sand}): sand-like particles (i.e. particles of high density) are removed in the sand removal unit
- suspended solids (X_{part}): are mainly removed in the settling unit and partly in the sand removal system
- colloidal pollution (X_{col}): is transformed into suspended solids into the flocculation-coagulation unit and removed in the settling unit
- soluble pollution (S_{sol} for carbon and S_{NH} for nitrogen) : part of the soluble carbon pollution is removed by flocculation-coagulation. S_{NH} (i.e. ammonia nitrogen) will not be removed in any of the SWT units.

2.3 Models

The whole system works by overflow. Mass balances are written for each unit. The sand removal unit and the settling unit are modelled as a 10 layers non-reactive unit (i.e. no biological reaction). The 9th layer (counting from bottom to top) is the feed layer for the sand removal unit and the 6th layer is the feed layer for the settling unit. The solid flux due to gravity is $J_s = v_s(X_{sc})X_{sc}$ where X_{sc} is the solid concentration. A double-exponential settling velocity function (v_s) (Takács et al., 1991) has been selected, with different parameters for the sand and the suspended solids:

$$v_s(X_{sc}) = \max\left[0, \min\left\{v'_0, v_0 \left(e^{-r_h(X_{sc}-X_{min})} - e^{-r_p(X_{sc}-X_{min})} \right) \right\}\right] \quad (1)$$

with

with

$$X_{min} = f_{ns}X_f \quad (2)$$

where v'_0 is the maximum settling velocity, v_0 the maximum Vesilind settling velocity, r_h the hindered zone settling parameter, r_p the flocculant zone settling parameter, f_{ns} the non-settleable fraction and X_f the total solid concentration in the unit influent.

For the soluble components, each layer represents a completely mixed volume and the concentrations of soluble components are calculated accordingly.

The flocculant (ferric salt) and coagulant (polymer) start to be added when the flocculation-coagulation unit is half full. For the flocculation-coagulation rates very simple functions have been assumed:

$$r_{f,sol} = \alpha_{pol} \cdot c_{pol} \cdot S_{sol} + \alpha_{fe} \cdot c_{pfe} \cdot S_{sol} \quad (3)$$

$$r_{f,col} = \beta_{pol} \cdot c_{pol} \cdot X_{col} + \beta_{fe} \cdot c_{pfe} \cdot X_{col} \quad (4)$$

Sand and sludge extraction, as well as reagents flows, are null when there is no flow at the inlet of the SWT unit.

3. BSM2 MODEL

Figure 3 presents a schematic overview of the BSM2 WWTP. Basically the activated sludge reactors are modelled using the Activated Sludge Model n° 1 (Henze et al. 1987) and the wasted sludge anaerobic reactor using the Anaerobic Model n° 1 (Batstone et al., 2002). A 609-day influent file is provided with the BSM2 layout. If the influent flowrate is greater than 60,000 m³/d, the exceeding flow is directed to the river. The plant design is based on a population of 100,000 inh. This implies that a flowrate adjustment is necessary between the designed SWT and the BSM2 WWTP. The BSM2 influent flowrate will be downscaled by a factor of 40,000 / 100,000 to be used as the SWT influent, when the wastewater flowrate is in the range of 0.15 – 3 m³/s. A maximal wastewater flowrate of 0.15 m³/s is sent continuously to the WWTP. As shown in Figure 2, the sludge flow from the SWT settler and the direct wastewater flow are

mixed before entering the WWTP. Prior to simulation by the BSM2 model, the influent flowrate is corrected by a factor of 100,000/ 40,000.

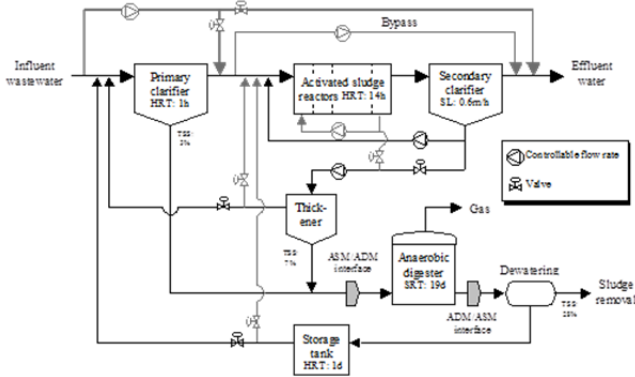

Fig. 3. General overview of the BSM2 WWTP.

The performance of the WWTP and the SWT+WWTP are assessed through an effluent quality index (EQI):

$$EQI = \frac{1}{t_{obs} \cdot 1000} \int_{t=245 \text{ days}}^{t=609 \text{ days}} \left(B_{TSS,bio} \cdot TSS_{bio,e}(t) + B_{COD} \cdot COD_e(t) + B_{NKj} \cdot S_{NKj,e}(t) + B_{NO} \cdot S_{NO,e}(t) + B_{BOD5} \cdot BOD_e(t) \right) Q_e(t) \cdot dt \quad (4)$$

where $TSS_{bio,e}$ is the total “biological” suspended solids concentration, as considered in ASM1, $S_{NKj,e}$ the Kjeldahl nitrogen, S_{NO} , the nitrates concentration, BOD_e , the Biological Oxygen Demand and COD_e the Chemical Oxygen Demand. B_j are weight factors. t_{obs} is the evaluation period, set to a full year (i.e. 364 days). Q_e is the total flowrate discharged into the river. BSM2 does not consider the inert solids such as sand in its influent composition. It takes into account the wastewater treated by the WWTP, the stormwater treated by the SWT unit, as well as any direct overflows into the river.

4. STATE VARIABLES INTERFACES

The state variables used in the SWT to describe physico-chemical phenomena and ASM1 state variables are different. Interfaces to transform the ASM1 state variables into the SWT and backward have been defined. The critical issues are the management of X_{sand} , since sand is not included in the definition of the ASM1 pollution, and the separation between the colloidal and particulate fraction of the pollution.

$$TSS_{bio} = \frac{1}{fr_{COD-SS}} \cdot (X_{B,H} + X_I + X_S) = X_{part} + X_{col} \quad (5)$$

where TSS_{bio} represents the total X biological suspended solids, $X_{B,H}$ the active heterotrophic biomass, X_I the particulate biologically inert organic matter, X_S the slowly biodegradable organic matter and fr_{COD-SS} the transformation factor between the chemical oxygen demand (COD) embedded in $X_{B,H}$, X_I and X_S and TSS_{bio} ($=1/0.75$)

$$TSS_{total} = TSS_{bio} + X_{sand} \quad (6)$$

$$X_{sand} = a \cdot TSS_{total} \quad (7)$$

$$X_{col} = b \cdot TSS_{bio} \quad (8)$$

$$X_{part} = TSS_{bio} - X_{col} \quad (9)$$

The sand and colloid fractions have been deduced from settling tests on real wastewater samples collected in the inlet chamber of the experimental SWT for these tests, the procedure developed by Chebbo *et al.* (2003) has been used.

$$S_{sol} = S_S + S_I \quad (10)$$

where S_S is the readily biodegradable substrate and S_I the soluble inert organic matter.

To calculate the distribution of particulate concentrations at the SWT exits in terms of ASM1 state variables, their ratios with respect to the TSS_{bio} are assumed to remain constant across the unit. Based on the average values calculated on the BSM2 influent file,

$$X_{B,H} = 0.101 \cdot TSS_{bio}/0.75 \quad (11)$$

$$X_S = 0.717 \cdot TSS_{bio}/0.75 \quad (12)$$

$$X_I = 0.182 \cdot TSS_{bio}/0.75 \quad (13)$$

$$X_{ND} = 0.326 \cdot TSS_{bio}/0.75 \quad (14)$$

$$S_I = 0.38 \cdot S_{sol} \quad (15)$$

$$S_S = 0.62 \cdot S_{sol} \quad (16)$$

$$S_{ND} = 0.25 \cdot S_{SN} \quad (17)$$

X_{ND} and S_{ND} represent the particulate and soluble biodegradable organic nitrogen, respectively.

5. PARAMETERS

The models have been implemented in FORTRAN: the differential equations are solved by a 4th order Runge-Kutta algorithm, with a step size of 0.005 hr. The following simulation methodology has been applied. The SWT is considered to be empty at the beginning of the simulation which lasts 609 days. For the BSM2 WWTP, after 10 days of simulation under constant inputs, the 609-day dynamic influent file was applied. The BSM2 WWTP was operated in an open loop. The last 364 days of the simulation are considered for performance assessment.

Figure 4 presents an example of the size distribution of the sand particles collected on the wastage line of the experimental sand removal unit after a rain event. 75% of the sand particles have a sieve diameter of between 180 μ m and 1 mm, with a D_{50} of 380 μ m. The maximum Vesilind settling velocity for the sand particles was chosen as 200 m/h (Dégremont, 2005).

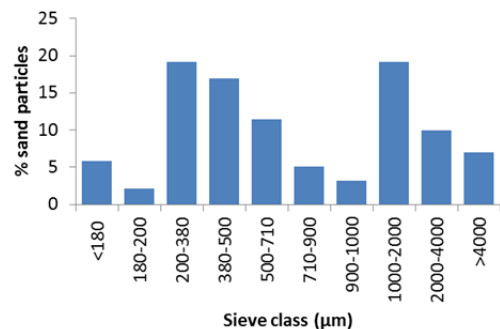

Fig. 4. Experimental size distribution of sand particles collected in the wastage line of the sand removal unit.

In Figure 5 examples of settling velocity distributions measured on different rain events at the inlet and the outlet of the sand removal unit are presented. If there is a clear decrease of the settling velocities between the inlet (where the settling velocity distribution is mainly governed by sand particles) and the exit, variability is observed: this is expected due to the variability of the rain events, in terms of intensity and length of preceding periods of dry weather. Based on this data, the maximum Vesilind settling velocity associated to non-coagulated particles in the sand removal unit has been set to 2 m/h and the maximum Vesilind settling velocity associated with coagulated particles in the settler has been set to 10.5 m/h. The other parameters are given in Table 1. 9% of the TSS at the inlet of the sand removal unit is associated with sand particles, when 3.6% of the COD is associated to colloids. Based on the experimental SWT the feedrates of iron salts and polymer suspension are equal to 1.05 m³/h and 0.02 m³/h, respectively.

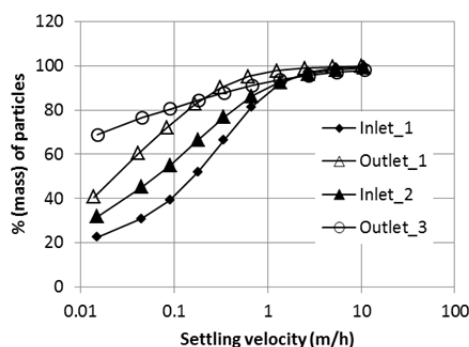

Fig. 5 Examples of settling velocity at the inlet (rain events 1 and 2) and the outlet (rain events 1 and 3) of the sand removal unit.

Table 1. Simulation parameters in terms of size and settling characteristics

	Sand removal	Settler
Volume (m ³)	1260	3920
Height (m)	6	8
v'_0 for sand (m/h)	200	200
v_0 for sand (m/h)	300	300
v'_0 for particles (m/h)	2	10.5
v_0 for particles (m/h)	4	20
r_h (m ³ /g)	2.86 10 ⁻³	
r_p (m ³ /g)	5.76 10 ⁻³	
f_{ns}	2.28 10 ⁻³	

6. RESULTS AND DISCUSSION

Figure 6 shows the flowrate variations in the SWT, prior to capacity adjustment for BSM2 WWTP. The present model assumes that the sub-units remain full even in the case of no rain for several days. In the real RWT, the content of the units are pumped to the WWTP after a few days. The reason is that the real SWT cannot be considered as non-reactive. Anaerobic reactions are very likely to occur along with production of methane and H₂S, which give rise to safety issues for operators.

As shown in Figure 7, sand is very efficiently removed from the system, most of it being trapped in the sand removal unit. Sand particles are carrying entrapped pollution (heavy metals, hydrophobic organic micropollutants such as polycyclic aromatic hydrocarbons). Although this sand is not accounted for in the BSM2 effluent quality index, this is a very positive point as this pollution is not discharged into the river.

Particulate pollution is only slightly retained in the sand removal unit, but its dynamics are dampened (Fig. 8). With the theoretical reagent dosage used, a good removal is achieved in the settler and the particulate pollution is concentrated into the physico-chemical (PC) sludge. Colloidal pollution is transformed into particulate pollution and eliminated from the water phase (Fig. 9).

Finally Fig. 10 depicts the fate of the soluble pollution, whose dynamics are also dampened but not eliminated from the water phase. Similar results are obtained for S_{NH} .

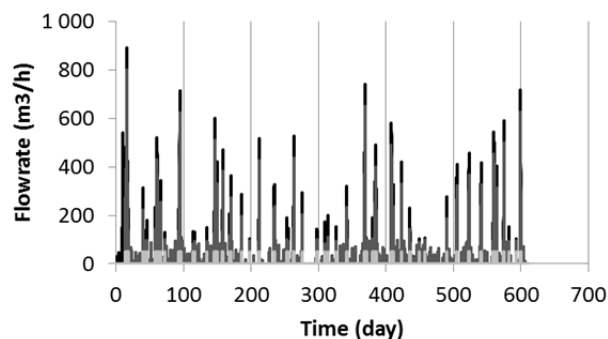

Fig. 6: Flowrate variations in the SWT. Black line = influent, medium grey line = discharge to the river, light grey line = PC sludge.

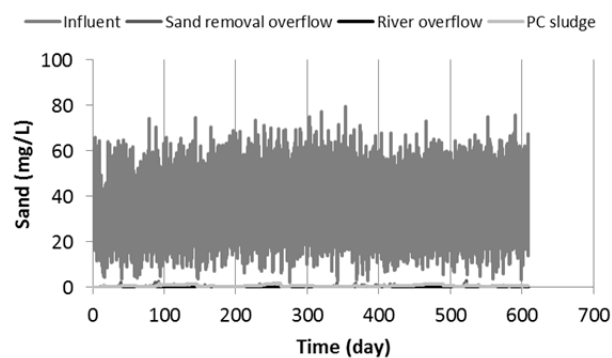

Fig. 7. Variations of sand concentration in the SWT

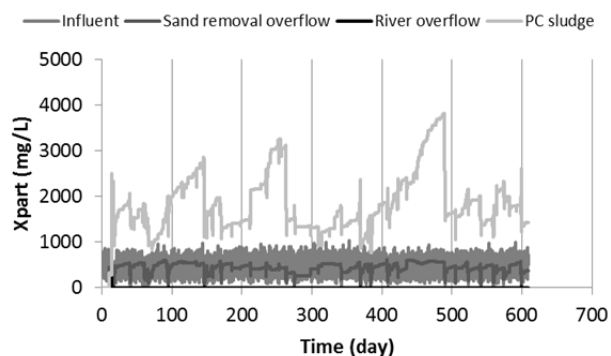

Fig. 8. Variations of the particulate pollution in the SWT

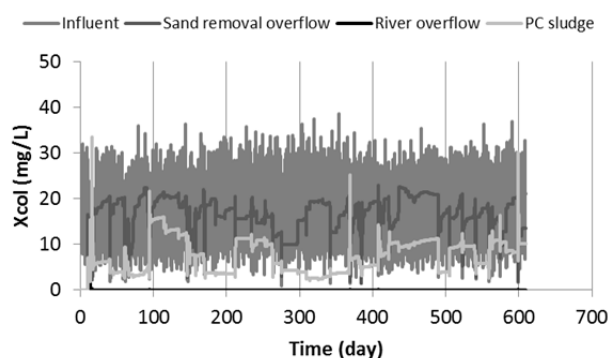

Fig. 9. Variations of the colloidal pollution in the SWT.

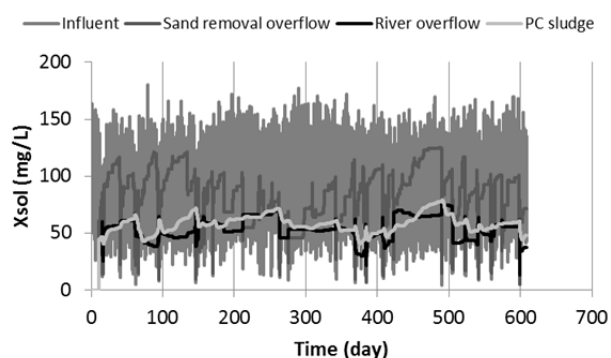

Fig. 10. Variations of the soluble pollution in the SWT.

Figure 11 presents the variations of the different flowrates at the level of the BSM2 WWTP after capacity correction. They are compared to the basic BSM2 influent flowrate. All the flowrate disturbances related to rain events have been suppressed and no direct overflow to the river occurs, since the flowrate that enters the WWTP (sum of the direct sewage flowrate and the PC sludge flowrate) is always less than 60,000 m³/d.

Table 2 summarizes the average exit concentrations, which take into account the effluent from the WWTP clarifier and the discharge to the river. A decrease is observed for S_{NH} (25%) and S_{NK} (13%). This effect is indirect as the nitrogen is not treated in the SWT. The exit BOD and TSS_{bio} decrease slightly (9% and 5% respectively) and no effect is seen on the exit COD . The effluent quality index decreases by 7.24%.

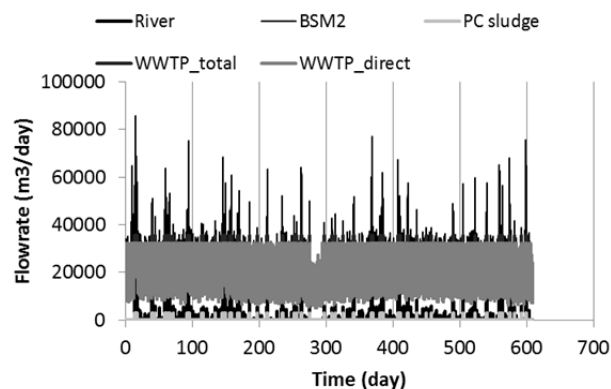

Fig. 11: Variations of flowrates in the WWTP

Table 2. Average pollution exit concentrations

	BSM2	SWT + BSM2
COD_e (mg/L)	50.1	49.3
BOD_e (mg/L)	2.77	2.5
$TSS_{bio,e}$ (mg/L)	15.9	15.1
$S_{NH,e}$ (mg/L)	1.65	1.23
$S_{NK,e}$ (mg/L)	3.73	3.22
$TN_e = S_{NO,e} + S_{NK,e}$ (mg/L)	11.2	11.2
EQI	5660	5250

The effect of the SWT on the effluent quality is not very great, apart from the sand-like particles which are efficiently removed from the stormwater. A clear effect however is seen on the percentage of time that the effluent violates the quality constraints (Table 3). This is calculated as the %time over the 364 days of the evaluation period for which the exit concentrations are larger than the constraints (Table 4). Total nitrogen (TN_e) is calculated as the sum of all the nitrogen species, including nitrates. This is mainly due to the hydraulic disturbances dampening in the SWT.

Table 3: BSM2 effluent quality constraints

Variable	Value
TN_e (g/m ³)	18
COD_e (g/m ³)	100 g
$S_{NH,e}$ (g/m ³)	4 g
$TSS_{bio,e}$ (g/m ³)	30
BOD_e (g/m ³)	10

Table 3. Percentage of time of violation of effluent quality constrains

	BSM2	SWT + BSM2
COD_e	0.06	0
BOD_e	0.22	0
$TSS_{bio,e}$	0.39	0
$S_{NH,e}$	8.29	4.30
TN_e	0.1	0.03

7. CONCLUSIONS

A stormwater treatment system based on physico-chemical operation units can indeed improve the performance of the downstream wastewater treatment plant, mostly by reducing the violations of the effluent quality constraints. However, such an improvement is mainly due to the dampening effect induced by the large volume of the tanks. Further improvement might be obtained by adjustment of the WWTP control system, which should be less disturbed by flow fluctuations. One has to still remember however that such system represents large investment expenditure and that running the flocculation-coagulation unit under very time-varying conditions is not easy. These difficulties, especially the adjustment of the reagents dosing during rain events, have not been considered here.

In the future, the STW model will be connected to a model of the Boudonville watershed, which will provide variations of the influent closer to the local situation than the BSM2 influent data file.

ACKNOWLEDGEMENTS

The authors wish to thank the Greater Nancy and its Sanitation Department for access to the experimental SWT. The financial support of ANRT, Zone Atelier du Bassin de la Moselle and the Lorraine region is acknowledged.

REFERENCES

- Batstone D.J., J. Keller, I. Angelidaki, S.V. Kalyuzhnyi, S.G. Pavlostathis, A. Rozzi, W.T.M. Sanders, H. Siegrist and Vavilin V.A. (2002). Anaerobic Digestion Model No. 1. *IWA STR No. 13*, IWA Publishing, London, UK.
- Chebbu G., M.C. Gromaire and E. Lucas (2003) The VICAS protocol: measurement of the settling velocity of particulate pollution in urban wastewater. *TSM*, no.12, 39-49.
- Dégrémont (2005) *Mémento Technique de l'Eau*, Lavoisier, Paris.
- Gurusamy Annadurai, S.S. Sung and D.J. Lee (2005). Optimization of floc characteristics for treatment of highly turbid water, *Separation Science and Technology*, **39**, 19-42.

- Henze M., C.P.L. Grady Jr, W. Gujer, G.v.R. Marais and Matsuo T. (1987). Activated Sludge Model n° 1, *IAWQ Scientific and Technical Report n°1*, IAWQ, London, UK.
- Jeon, J.C., K.H. Kwon, L.H. Kim, J.H. Kim, Y.J. Jung and K.S. Min (2013). Application of coagulation process for the treatment of combined sewer overflows (CSOs), *Desalination and Water Treatment*, **51**, 4063-4071.
- Nopens I., L. Benedetti, U. Jeppsson, M.-N. Pons, J. Alex, J. B. Copp, K. V. Gernaey, C. Rosen, J.-P. Steyer, P. A. Vanrolleghem (2010) Benchmark Simulation Model No 2: finalisation of plant layout and default control strategy, *Water Science and Technology*, **62**, 1967-1974.
- Takács I., G.G. Patry and D. Nolasco (1991). A dynamic model of the clarification thickening process, *Water Research*, **25**, 1263-1271.
- Trejo-Gaytan, J., P. Bachand and J. Darbie (2006). Treatment of urban runoff at Lake Tahoe: Low-intensity chemical dosing. *Water Environment Research*, **78**, 2487-2500.
- US-EPA, *Combined Sewer Overflow Technology Fact Sheet Screens*, EPA 832-F-99-040, Office of Water, United States Environmental Protection Agency, Washington, DC.