

The next step in evolution
CENTUM VP



CENTUM[®]VP

The core platform for Yokogawa VigilantPlant[®] Solutions.
Designed to empower all members in the production
value chain to See Clearly, Know in Advance, and Act with Agility

Bulletin 33L01A01-40E

www.yokogawa.com/centumvp

vigilantplant.[®]
The clear path to operational excellence

YOKOGAWA 

The clear path to operational excellence



In a quickly changing industry it's not only about technology, but more importantly, it's about helping people get their jobs done right. As the originators of the first DCS, known as CENTUM, we've spent more than 30 years paying careful attention to what plant managers, engineers, and control room operators have been saying. We're proud to recommend to you the new CENTUM VP, the next evolutionary step bringing better information visibility, performance foresight, and operational agility. At the end of the day, we want you to head home with the knowledge that you succeeded.



vigilantplant.[®]



CENTUM[®] **VP**

01

02

The CENTUM VP advantages

CENTUM VP ushers in an operating environment that keeps everyone fully aware, well informed, and ready to face the next challenge.

Information visibility

**SEE
CLEARLY**

CENTUM VP makes critical plant information visible in a meaningful and actionable manner.
CENTUM VP captures plant-wide data without delay and delivers the right information to the right people at the right time. Reducing blind spots while preventing information overload, CENTUM VP keeps people's attention firmly focused on operational targets and business goals.



Performance foresight

**KNOW
IN ADVANCE**

CENTUM VP delivers the knowledge necessary to anticipate changes and to make fast, informed decisions.
CENTUM VP enables quick synthesis of analytic insights from the historical, real-time, and future-predictive perspectives. Allowing people to make fast intelligent decisions every day, CENTUM VP helps your business avoid costly surprises.



Operational agility

**ACT
WITH AGILITY**

CENTUM VP helps to implement decisions throughout the value chain without delay.
CENTUM VP speeds up task coordination and navigation, enhancing the flexibility of production and adaptability of business. Constantly systemizing and automating operational best practices, CENTUM VP prevents delays and preempts bottlenecks.



Operations



Safe and unified plant operations
Universal interface for control, safety, and asset intelligence
Embedded mechanisms to prevent information overload

Non-stop improvement
Continuous systemization of operational best practices and context specific operational advisories

Production Management

Faster Plan, Do, Check, and Act cycle for agile adaptation
MES and enterprise system integration using S95 and B2MML standards

Secure and standard-based information integration
Built-in control network security certified by experts



Maintenance



Continuous evolution without compromising asset availability
Evergreen evolution with online upgrades and modifications
Most reliable platform with no single point of failure

Long-term investment protection
Step-by-step phased migration paths incorporated before any new release. We have over 30 years of backward compatibility.

Project

Faster project execution with fewer integration risks
Single-source integrated solutions for control system (DCS), safety instrumented system (SIS), embedded plant information management system (PIMS), intelligent RTU & SCADA, and turbine controller

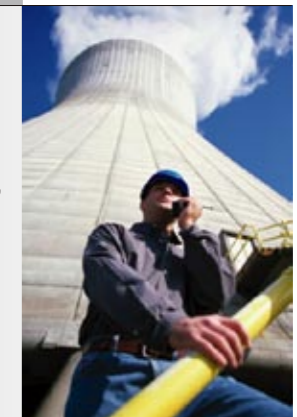

CENTUM VP

A simple & common architecture covers a variety of plant sizes & industries

CENTUM VP has a simple & common architecture consisting of human machine interfaces, field control stations, and a control LAN. These three basic components support facilities from the tiny to the very large and complex with up to 1,000,000 tags.

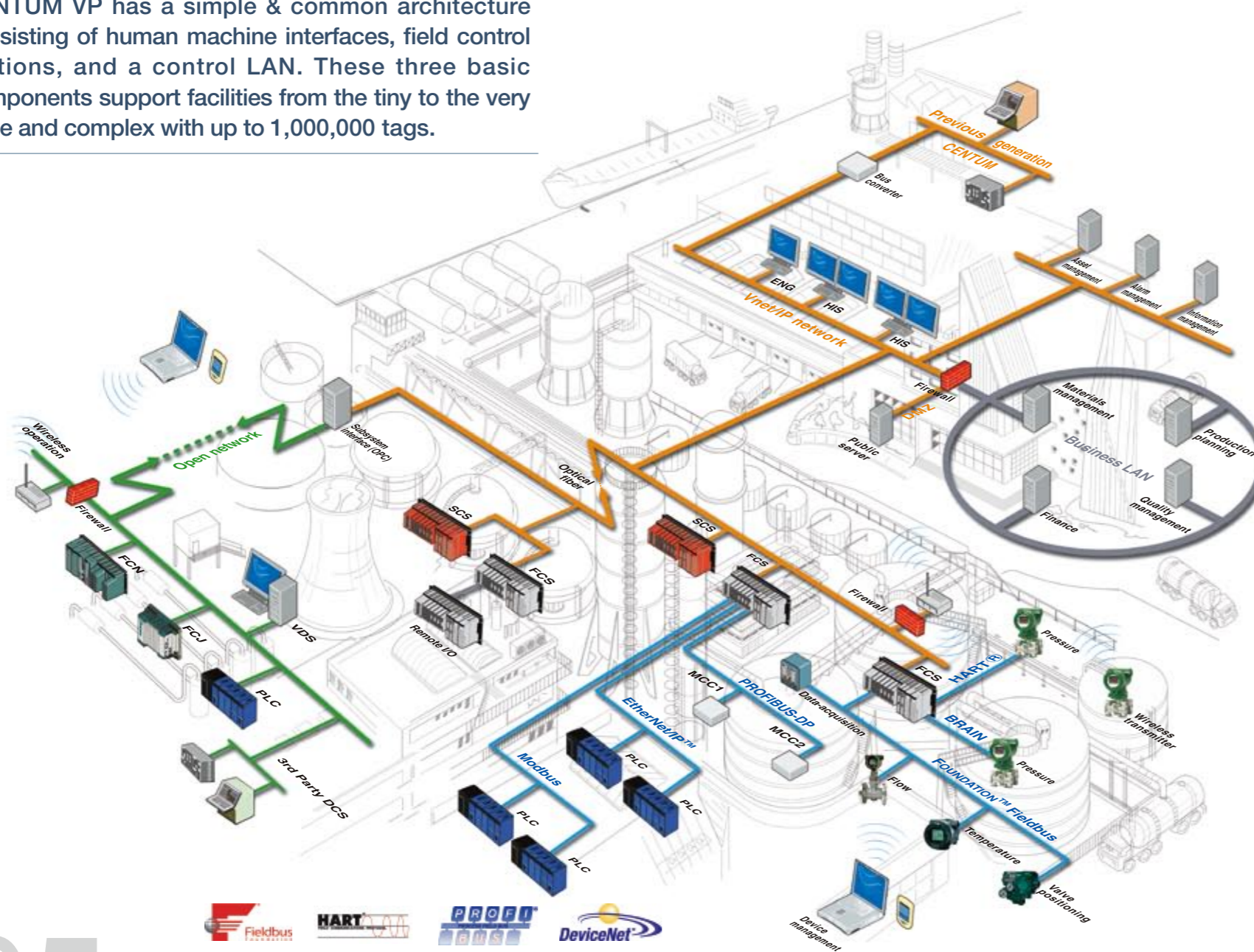

Human Interface Station (HIS)

Windows based operating system, commercial-off-the-shelf PC hardware, and optional specialized operator keyboard for a large variety of operator consoles

Engineering Station (ENG)

With the same PC features mentioned above, this includes a comprehensive engineering package for all plant environments.

Field Control Station (FCS)

100% Yokogawa manufactured. This is the core of CENTUM VP's high availability/reliability, continuing the CENTUM heritage.

Control LAN (Vnet/IP)

Vnet/IP, an IEEE802.3 Ethernet compliant redundant network operating at 1 Gbps, incorporates Yokogawa's technology, achieving deterministic, reliable, and secure communications.

Digital Fieldnetworks

CENTUM VP supports FOUNDATION™ fieldbus, HART, PROFIBUS-DP, DeviceNet, Modbus, Modbus/TCP, and Ethernet/IP.

Bus Converter (BCV)

Interface hardware that connects multiple control networks. It also connects previous CENTUM series systems to CENTUM VP.

Operational Excellence Software Suite

A software suite for the Windows platform that supports plant operations and maintenance improvement, such as plant safety, plant asset management, production management, and optimization

System Integration OPC Station (SIOS)

Used to integrate other companies' PCS's (process control systems) to the CENTUM VP system.

Safety Control Station (SCS) - ProSafe-RS

This is Yokogawa's TÜV SIL3 certified premier safety instrumented system. It incorporates Yokogawa's own Pair and Spare and Vnet/IP technologies and offers unprecedented synergy with CENTUM VP.

Network-based System Controllers - STARDOM

Yokogawa's intelligent-hybrid remote telecommunication controllers are ideal for the oil and gas upstream market. They can be seamlessly integrated, via the SIOS, to CENTUM VP.

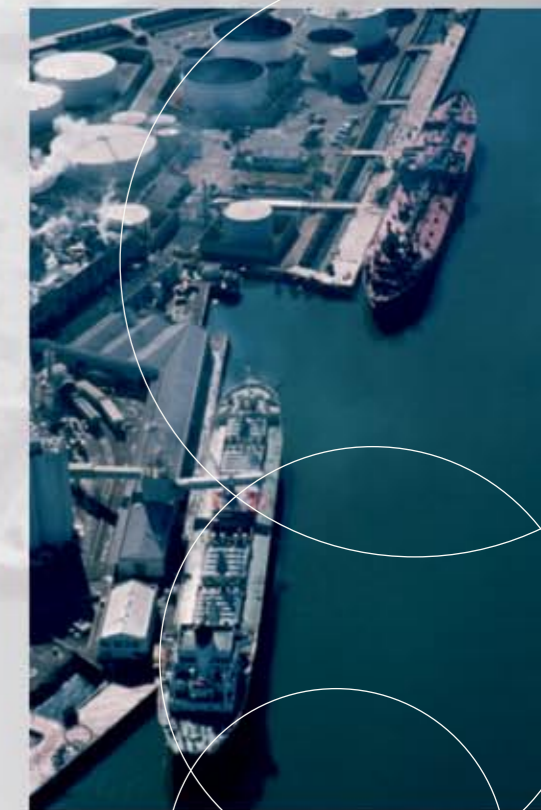

Intuitive human machine interface for plant operation

CENTUM VP has a new HMI (human machine interface) that makes information access quicker and more intuitive.

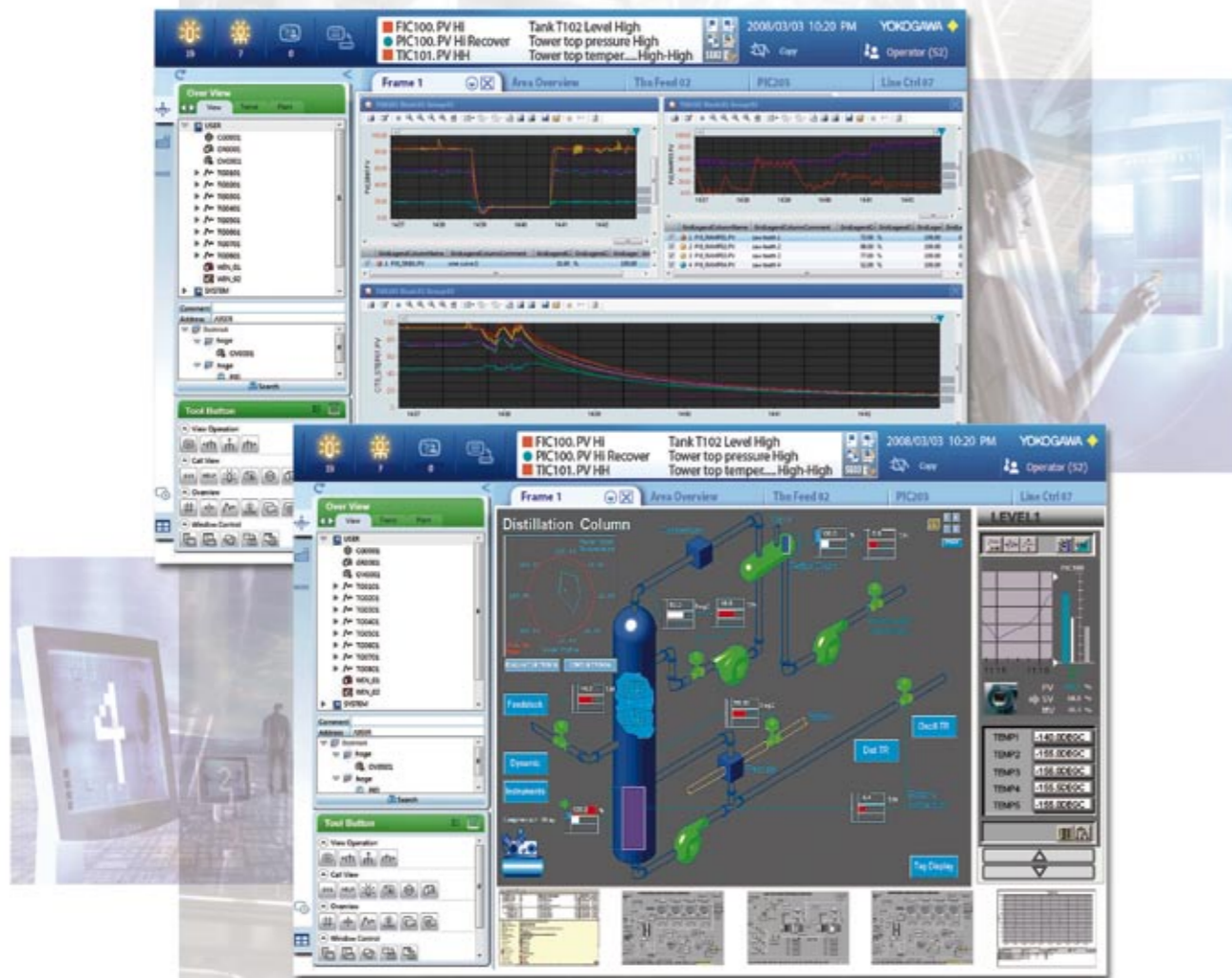

True Integration of Safety Excellence, Asset Excellence, and Production Excellence

CENTUM VP achieves the operational excellence that is the focus of Yokogawa's Safety Excellence, Asset Excellence, and Production Excellence initiatives. It offers integrated viewing and data handling functions. For example, alarms from the ProSafe-RS Safety Instrumented System and Plant Resource Manager, Yokogawa's Asset Management product, can be seen and handled seamlessly in the HIS. You can also see historical data from Plant Information Management System in a window at the HIS. All plant process data, device data, procedures, and documents are handled by CENTUM VP.

EEMUA Guidelines for Alarm System Design

Based on the latest edition of the EEMUA* #191 guidelines, Yokogawa has developed a Consolidated Alarm Management System for the process operator in the HIS.

*Engineering Equipment & Materials Users' Association

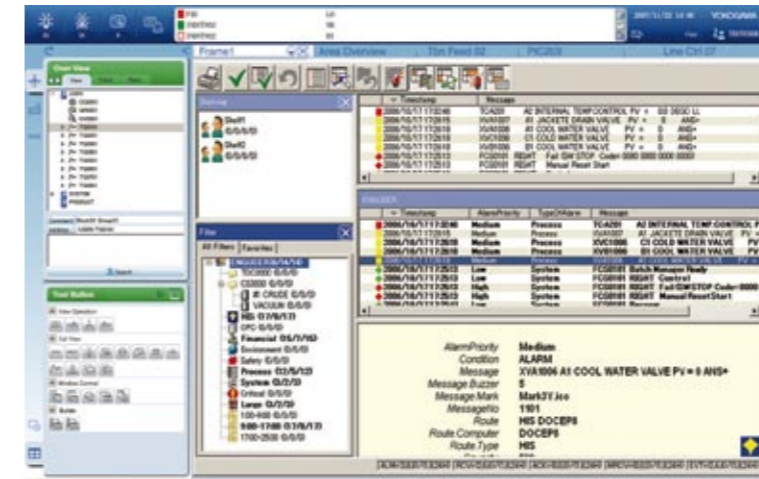

No Single Point of Failure

The HIS runs on Windows and offers customers the convenience of using commercial-off-the-shelf hardware. Although the reliability of a PC is relatively low, it does not affect the total reliability of the process operator function. Within CENTUM VP the HIS is not server-client dependent. Therefore multiple HISs can support each other and there is no single point of failure. The CENTUM VP supports multiple operator console configurations: desktop, open-bay console, hardened enclosed-bay console, and custom consoles.

Multiple-monitor Support

The amount of information available to process operators has been increasing and greater flexibility is demanded from the HMI. For many different configurations, one HIS supports to four monitors as well as wide flat panels (16:10 aspect ratio) of 24-inch and 30-inch sizes.

Safety and reliability are the core fundamentals of all production activities

All field control stations (FCSs) in the CENTUM series, including software and hardware, have been developed by Yokogawa. We know every single bit of software and hardware to maintain a 99.9999% availability service record.



Compact Design

Compact components reduce the overall "footprint" of the control system, allowing savings from smaller equipment rooms. For convenience, both the FCS and its I/O node units can be placed in remote classified locations (IEC Zone2/Class I Div. 2), providing installation savings.

V net and Vnet/IP

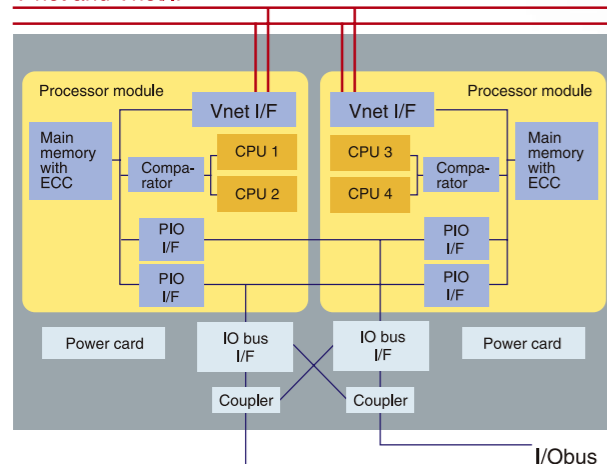

Dual-redundancy and Reliability

There is no single point of failure in Yokogawa's FCS! The processor modules, power supplies, and I/O modules including the communication bus support a redundant configuration. In this configuration, which is known as "Pair and Spare," the reliability of calculation results is guaranteed through real-time validation.

Two processor modules have two CPUs each. CPU 1 and CPU 2 in the primary processor module are always comparing the calculation result, and if the results do not match, the first processor module goes into maintenance mode while the secondary processor module takes over process control. In order to make this switch over seamless, CPU 3 and CPU 4 are also calculating and comparing the results while the primary processor module is active. Pair and Spare is Yokogawa's unique technology, supporting impressive levels of availability for CENTUM and ProSafe-RS. This architecture has been approved by TÜV Rheinland for safety instrumented systems. The ProSafe-RS certification period was unprecedentedly short for TÜV and this was due in-part to our Pair and Spare technology.

Online Maintenance

Through an online maintenance function, FCS applications can be modified without interrupting process control.

Open Structure and High Reliability

Yokogawa is committed to reducing costs for our customers by enabling the use of commercial off-the-shelf technology where appropriate. Third-party cables, switches and other network communication devices can be used with Yokogawa's Ethernet based Vnet/IP. Plant reliability is in no way compromised as the communication response is guaranteed (deterministic as opposed to probabilistic) thanks to Yokogawa's renowned reliability, dedicated protocol, and redundant configuration.

Function Blocks

The CENTUM VP provides functional blocks for monitoring, control, manipulations, calculations, logic functions, and sequences. Not only continuous control but also advanced control, complicated sequence control, and batch control are all executed in a redundant, secure, and reliable controller environment. Plant systems can be flexibly designed, ranging from small- to large-scale, through the combination of these control blocks.

Subsystem Integration and Digital Fieldnetworks Support

To meet the growing need for communication with manufacturing equipment including variable speed drives, PLCs, and "smart" motor protection relays for operation and monitoring, as well as with analyzers, weighing machines, smart instruments, and other instruments used for product inspection, CENTUM VP supports a wide variety of communication interfaces and digital fieldnetworks such as FOUNDATION™ fieldbus, PROFIBUS-DP, Modbus RTU, Modbus TCP/IP, and DeviceNet.

Unit Instruments

The multiple devices of a process facility which would previously have been handled individually can now be defined, operated, and monitored as a single unit, simplifying operation. Unit instruments can be applied to batch processes and continuous control processes that require complex management, expediting overall plant operation.

How does CENTUM VP employ "openness" in a control system?

The technological innovation achieves the world fastest, open, reliable and real-time communication. Customer centric mindset maintains the true interoperability.

Global Host Interoperability Support Test (HIST) Network

In the arena of FOUNDATION™ fieldbus, manufacturers are bringing new devices to market all the time, in addition to upgrading older instrumentation. Therefore, interoperability has always been a key issue with Yokogawa. To facilitate project management on a global basis, Yokogawa has formed a global HIST network. Test sites in Japan, the Netherlands, Houston (USA), and Singapore make sure the interoperability between Yokogawa systems and non-Yokogawa devices is acceptable. All test results are reported to Japan. This information is disclosed at <http://www.yokogawa.com/fbs/Interoperability/fbs-hist-en.htm>



1Gbit, World's Fastest Open Control Network

The real openness of a control LAN does not just come from using TCP/IP technology. Yokogawa's Vnet/IP provides open, reliable, and real-time broadband communications. Both CENTUM and non-CENTUM components can be connected to the network. The open communication band does not affect process control data communications nor does it impact the performance and security aspects of the control communications band. The Yokogawa system guarantees data updates every second in the HIS, even with a 1,000,000 tag project. Vnet/IP offers one millisecond time synchronization among all stations on Vnet/IP. A third-party organization has certified the security robustness of Vnet/IP and communications to the CENTUM VP FCS.



True Interoperability

Interoperability of Yokogawa CENTUM systems with the "outside world" begins with OPC. CENTUM VP utilizes an OPC server that meets the demands of information flow, advanced control, and alarm/event management. Our customers enjoy solid performance and wide flexibility of our OPC server for their integration projects. Yokogawa maintains interoperability with all intelligent instrumentation and deployed fieldbuses.

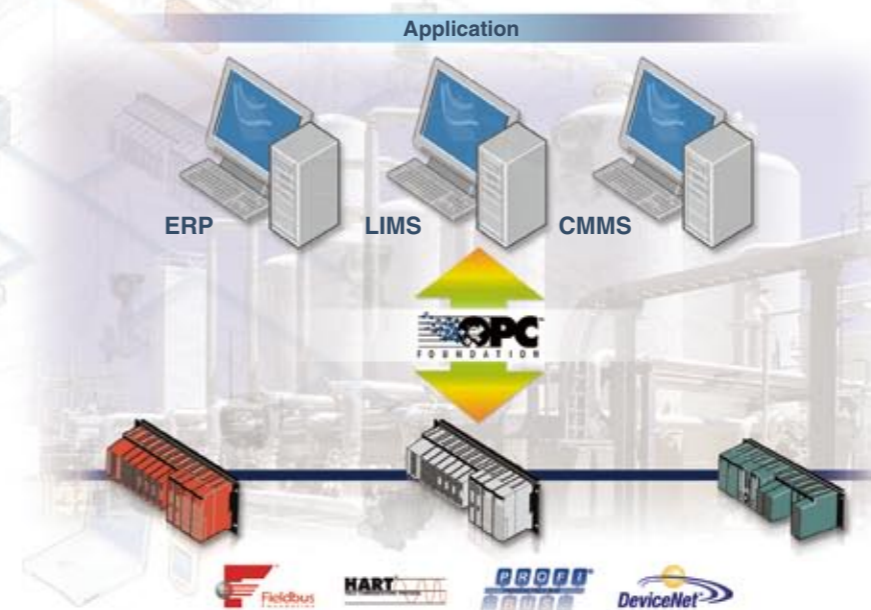

Operational Excellence Software Suite



The CENTUM VP simple and common architecture covers not only continuous and batch control but also manufacturing operations management. The Operational Excellence Software Suite operates on Windows PCs that are directly connected to the Vnet/IP network. Single-source seamless integration eliminates redundant engineering between control system engineering and Operational Excellence Software Suite engineering. For example, once you configure the function blocks in the FCS, the information of the function blocks is available in the plant information management engineering tool. This software suite integrates with third-party information systems through OPC interfaces.

Plant Information Management

All plant information such as process and batch data, alarms and events, and plant resource and diagnosis data are handled by plant information management. This gathers data directly from the system. Thanks to Vnet/IP functionalities, data availability and gathering is dramatically improved compared to an OPC interface. Plant information management supports the OPC interface for third-party control system integration.

Consolidated Alarm Management

Consolidated alarm management supports Six Sigma DMAIC (Define, Measure, Analyze, Improve, Control) for your alarm management based on the latest EEMUA #191 alarm management guideline. It provides additional useful tools such as graphical historical data analysis and automatic alarm reduction. Sequence of event management functions are also included.

Operation Navigator

Operation Navigator is an operation support tool that assists quick and accurate decision-making and operation. Operation Navigator automates standard operating procedures (SOPs) and provides early detection of process and device abnormalities. Operation Navigator also provides easy to use tools that allow operators to create and automate their own operating procedures.

Plant Resource Management

With plant resource management and intelligent field devices, operators and maintenance personnel can monitor the condition of plant assets remotely. Plant resource management's diagnostic functions detect early signs of performance deterioration such as valve sticking and impulse line blocking. By helping curtail excessive preventive maintenance and enabling higher level predictive and proactive maintenance, plant resource management opens the way to asset predictability.

Advanced Process Control

CENTUM VP has a variety of advanced process control solutions. The Multivariable Model Predictive Control Package uses a model-based multivariable predictive control algorithm that takes various conditions among process variables into account, such as constraints and economic efficiency, in order to perform stable, economically optimal operation. The Robust Quality Estimator predicts the qualities of intermediate and final products in real time using associated process measurements such as temperature, pressure, and flow.

Batch

CENTUM VP has a batch plant information management system that is compatible with the ISA-88 (IEC 61512) batch control standard and 21 CFR Part 11 regulations. The Web-based trend, report, and analysis functions allow batch process data to be evaluated in terms of productivity, equipment, and recipes.

OPC

True interoperability is the policy of CENTUM VP's OPC development. This is compliant with the OPC standard and enables upper-level applications to access data from the production control system. Incorporating data access (DA), alarm and event (AE), and historical data access (HDA) services, OPC provides for high throughput access to OPC clients.

Production to Business Integration

Production to business integration is CENTUM VP's solution to the challenges of integrating the business and control domains. Collaborative production management requires the integration of key systems to facilitate the creation of usable information. These systems typically include process control systems, historians, computerized maintenance management systems (CMMS), laboratory information management systems (LIMS), planning & scheduling, inventory management, and enterprise resource planning systems (ERP).

CENTUM VP stands by its automation users over the entire plant lifecycle

CENTUM VP brings your cost down over the lifecycle of your plant. Maintenance is less frequent, upgrade is easy, expansion is smooth, and even revamp is speedy.

Precise Project Cost Estimation

In CENTUM VP, the FCS application load can be quickly calculated in the design stage and easily monitored when on-line. During engineering design, the precise number of FCSs required is known. As the project progresses, with engineering changes, cost changes are minimized due to the simple licensing structure incorporated into CENTUM VP. This covers both the addition of stations and tags. To provide the most economical system, CENTUM VP has only two tag license boundaries: the 8,000 tags for entry level and small system architectures, and the 100,000 tags for medium to large scale plant systems. When linking multiple plants together, then we have a one-time 1,000,000 tags.

Virtual Test Function

A virtual FCS and HIS environment is available where both the control and operator functions of the CENTUM database can be tested without FCS hardware. Application testing and engineering time are dramatically reduced, accelerating project progress and reducing engineering cost. For system expansion and modification, applications can be tested and verified without any impact on the actual plant operation. Where ProSafe-RS is also a part of the system, then virtual testing is also available together with CENTUM VP. Our virtual test function is also a key component in building an operator training system (OTS).

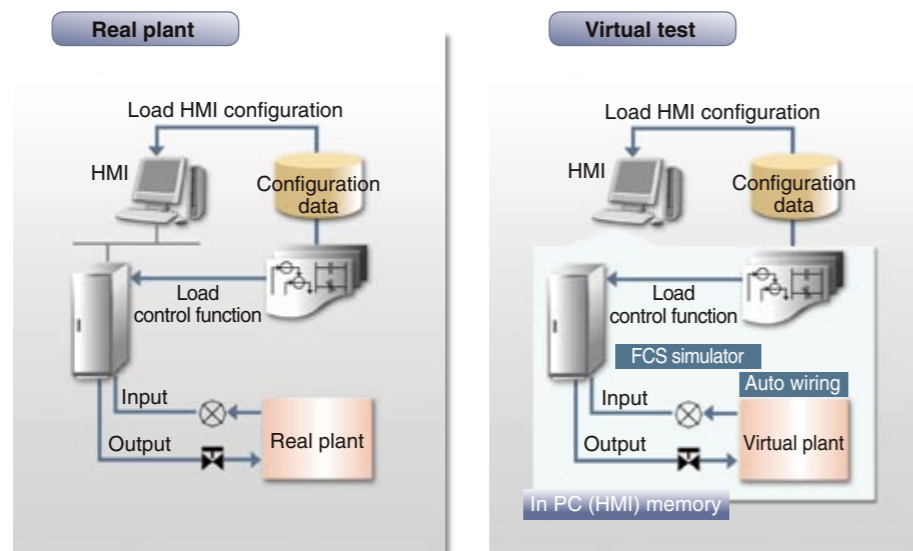

15

Upgrading

As part of lifecycle cost management, Yokogawa has paid particular attention to upgrading all CENTUM systems. It is simple, quick, and direct. All CENTUM VP stations that are PC-based can be upgraded with one mouse click. For the FCS, if you are not using any new functions, then upgrading is not needed. Where the latest functions are desired, it takes just one mouse click to execute an FCS upgrade.

Multiple Project Connection

Customers are demanding different sites to be linked together so that bi-directional operation can be made more efficient. Yokogawa provides a Multiple Project Connection package to connect several CENTUM VP sites together and link older CENTUM sites.

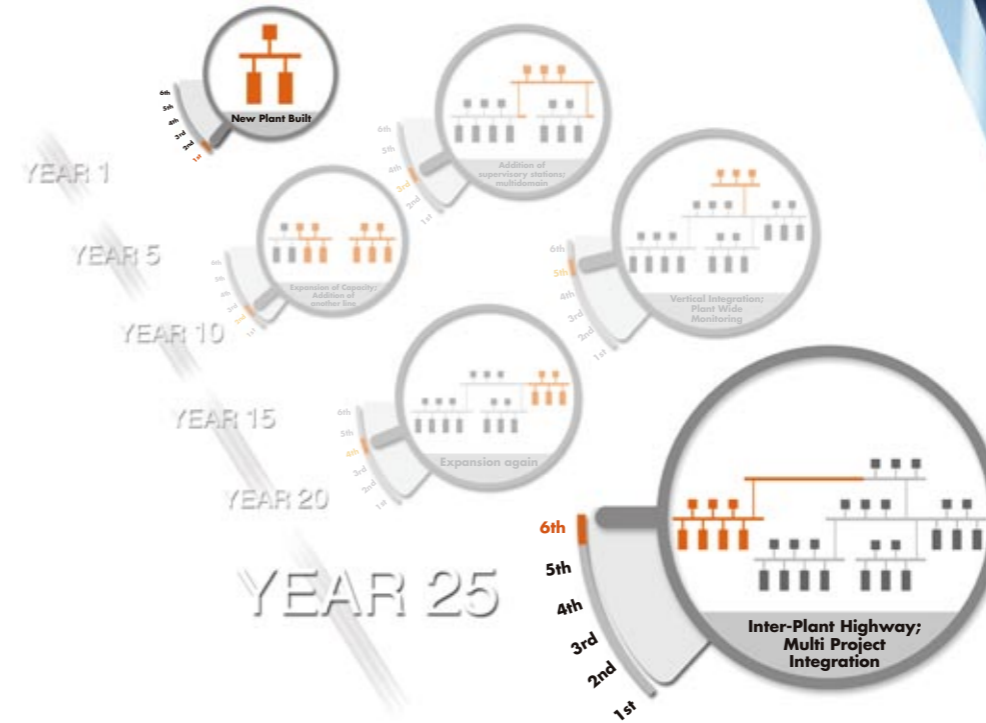

Migration

Migrating from CENTUM CS 3000 to CENTUM VP is accomplished without manual conversion. It is a standard function of our engineering configuration tool. Older CENTUM systems require Yokogawa conversion tools for the older database designs. Tools are also available for migrating from a few legacy/older third-party DCS systems to CENTUM VP.

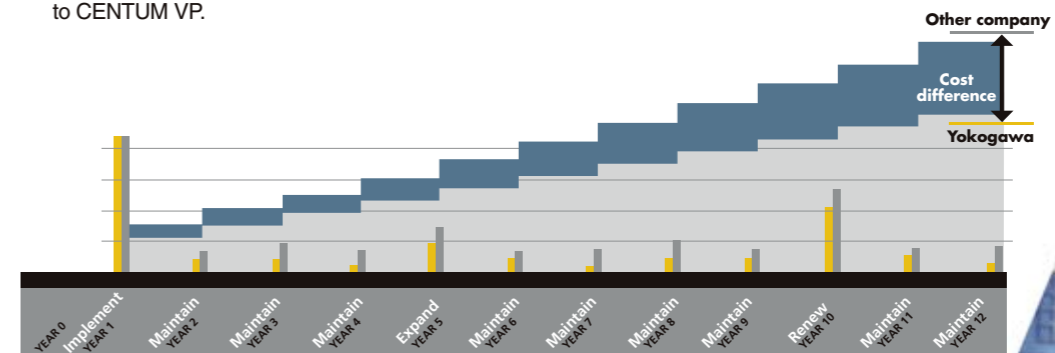

16

Services: Lifecycle Management Program

A customized program that fits the unique needs of your plant and business

The Lifecycle Management Program is an integrated package of solution services that optimizes maintenance by tailoring it to the customer's equipment lifecycle. This program meets diverse needs by creating a lifecycle plan for each customer's system, and based on it, selects and combines the most suitable services from a variety of options.



Rich building blocks to address your needs

Maintenance Management



- Vigorous maintenance plans and support for all unique needs
- Pinpoint identification of problems through condition based maintenance

Inventory Management



- Parts stocking for emergencies
- Minimize capital investment with parts management program
- Operate your plant(s) and equipment with the latest hardware/software

Safety Improvement



- Change the method of responding to alarms
- Assure that the systems are well protected through the Yokogawa network service consultation & solutions

Service & Support



- 24/7 response
- Single contact for all customer service needs

Operator Effectiveness



- Wide range of training courses to meet all needs

Migration Support



- Minimize the threat of diminishing resources and obsolescent parts
- Reduce the risk of operating older control systems with our proven migration roadmap

Productivity Improvement



- Standardization of process
- Track improvement performance
- Optimizing decision support

Vigilant engineers making history with CENTUM

CENTUM has grown with our customers over the past 30 years and is the clearest sign of our unwavering focus on maintaining continuity in solutions and services. Look to CENTUM for another 30 years of consistency and continuous improvement. With Yokogawa, commitment means building the future to last.



We have developed CENTUM VP in Singapore.



We have developed CENTUM CS 3000 and CENTUM VP.



We have developed CENTUM CS, CENTUM CS 3000, and CENTUM VP.



We have developed CENTUM V, CENTUM-XL, CENTUM CS, CENTUM CS 3000, and CENTUM VP.



CENTUM VP enables VigilantPlant Operational Excellence Model

Excellence in production, asset, and safety sustained over the life cycle of your plant.

- **Production Excellence** for operational agility and adaptability
- **Asset Excellence** for asset availability and utilization
- **Safety Excellence** for health, safety, and environmental (HSE) protection

The VigilantPlant Operational Excellence Model aims to sustain your profitable business growth by enabling excellence in three key aspects of plant operations over the life cycle of your plant.

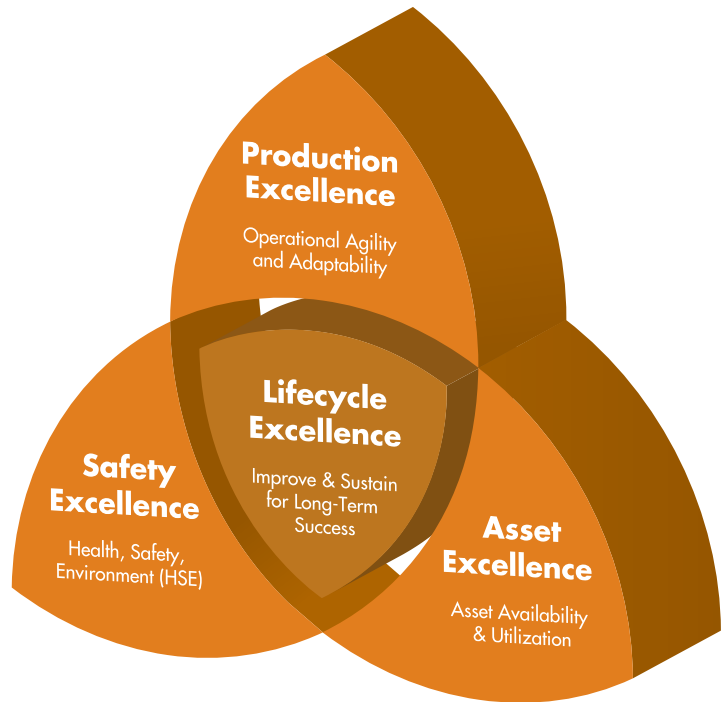

A Yokogawa Commitment to Industry

vigilance[®]



What does Yokogawa **vigilance** mean to the future of your business? **Quality.** Through products that are built from the ground up and tested to the last hour, you're ensured continuous operation and more uptime. **Innovation.** Your business will benefit from new insights and capabilities, bringing true predictability to your process. **Foresight.** As the market changes, you'll have solutions that give you the continuity and flexibility to plan ahead and grow. Our partners know the difference. With Yokogawa, you can count on a lifetime of plant efficiency, from instrumentation to operation support. Let us be vigilant about your business.

YOKOGAWA ELECTRIC CORPORATION

World Headquarters

9-32, Nakacho 2-chome, Musashino-shi, Tokyo 180-8750, Japan
<http://www.yokogawa.com/>

YOKOGAWA CORPORATION OF AMERICA

2 Dart Road, Newnan, Georgia 30265, USA
<http://www.yokogawa.com/us/>

YOKOGAWA EUROPE B.V.

Databankweg 20, 3821 AL Amersfoort, The Netherlands
<http://www.yokogawa.com/eu/>

YOKOGAWA ENGINEERING ASIA PTE. LTD.

5 Bedok South Road, Singapore 469270, Singapore
<http://www.yokogawa.com/sg/>

YOKOGAWA CHINA CO., LTD.

K. Wah Centre 28, 29F, 1010 Huai Hai Zhong Rd., Shanghai 200031, China
<http://www.yokogawa.com/cn/>

YOKOGAWA MIDDLE EAST B.S.C.(c)

P.O. Box 10070, Manama
 Building 577, Road 2516, Busaiteen 225, Muharraq, Bahrain
<http://www.yokogawa.com/bh/>

Trademarks

CENTUM, Vnet/IP, ProSafe, STARDOM, vigilance and vigilantplant are either trademarks or registered trademarks of Yokogawa Electric Corporation. All other company brand or product names in this bulletin are trademarks or registered trademarks of their respective holders.

Represented by:

