

Control structure selection for the deethanizer column from Mongstad/Statoil

Eduardo Shigueo Hori, Sigurd Skogestad

April 27, 2007

Abstract

The selection of a good control structure for a distillation column is important for the plant operation because it can affect its operability. In this work, it is studied the control structure selection of a deethanizer distillation column from Mongstad/Statoil. This is a multicomponent distillation column with a partial condenser and a vapor distillate flow. Having a very small distillate flow rate (1% of the feed flow rate), this column presents some difficulties for pressure control. The simulations are done in ASPEN Plus and ASPEN Dynamics. The main objective is to find a structure that minimizes the effect of the disturbances and implementation error (noise and bias) in the top and bottom compositions (indirect composition control). The results show that it is better to control temperatures in the top section where the gains are higher and, as this is a multicomponent column, the two-point temperature control does not improve the control system performance, confirming the results obtained by Hori and Skogestad (2007b). As the most important disturbance for this column is the feed flow rate, the results also show that we should ratio the available manipulated variables with feed flow to improve the control performance. Also, the simulations show that it is possible to control the pressure using the distillate flow rate if we also close a temperature loop.

1 Introduction

In this work, we want to simulate, in ASPEN Plus and ASPEN Dynamics, the deethanizer distillation column from Mongstad/Statoil. This column has operational problems and our objective is to find a good control structure for it. The column has 36 trays and a partial condenser. The top product is vapor and the bottom product is liquid.

Partial condensers are used when there are very light components in the feed to the column that would require a high column pressure or a low condenser temperature, so the use of a partial condenser can avoid the use of costly refrigeration (Luyben, 2004).

The objective of the column is to separate ethane (C_2) from propane (C_3). Although the maximum allowed concentrations of C_3 in the distillate is 10% (mol fraction) and the maximum concentrations of C_2 in the bottom flow is 1% mol, we are running the simulations in a operation point closer to the operation point used in the real plant. So, in this case, the top composition is around 15%. This difference is not significant enough to invalidate the results obtained in this work, i.e., the same conclusions can be extended to the desired objective of the column (maximum of 10% of C_3 in the distillate, D).

The feed composition is (in % mol): 2.1% of ethane (C_2), 59.8% of propane (C_3), 12.5% of isobutane ($I - C_4$), 25% of butane ($N - C_4$), and 0.6% of propane ($N - C_5$). The total feed flow

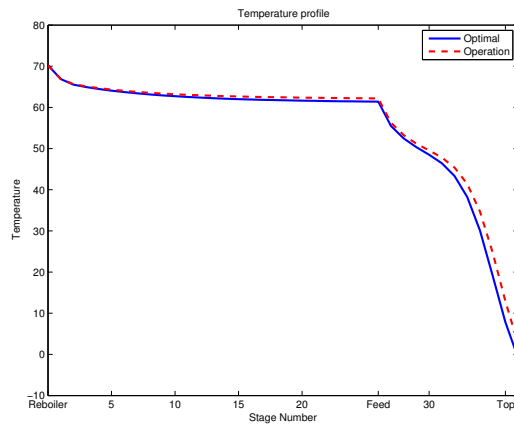

Figure 1: Temperature profile ($^{\circ}\text{C}$).

rate is 150 ton/h . The column is fed in tray 26. As the feed is already very low concentrated in ethane, the distillate flow rate will be very small (around 1% of the feed flow rate). Although this could cause some difficulties for pressure control, the results show that this is not a big problem if we consider that a temperature loop is also closed.

The most important disturbance in this column is the feed flow rate. It can change from 75 ton/h to 150 ton/h during the operation in few hours, as is shown in Figure 41, where the feed flow rate decreases about 45 ton/h in less than 1 hour.

Ralston *et al.* (1985) presented an indirect dual composition control of a deethanizer. They use a combination of a feedforward and a feedback algorithms. The control structure used was:

- The bottom level is controlled by bottom flow rate (B)
- The reflux drum level is controlled by condenser duty (Q_c)
- The pressure is controlled by distillate flow rate (D)
- A temperature is controlled by reboiler duty (Q_b)

To complete their control structure, Ralston *et al.* (1985) applied a feedforward algorithm where they measure the feed flow rate e composition and manipulate the reflux flow rate (L). Except for the feed forward part, this control strategy is similar to control structure 2 (see section 3.2). Differently from our case, this deethanizer has a high distillate flow rate, so it probably does not have the saturation problems that we found for structure 2 shown below.

The objective of this work is to find a good control structure that keeps, indirectly, the top and bottom compositions of the deethanizer close to their desired set points. In the simulations presented we added noise and bias in all measurements.

2 Profiles

The first step in this project is to do a steady-state simulation. This simulation was done in ASPEN Plus. The data used came from the process and instrument diagrams (P&ID) provided by Statoil.

Figure 1 compares the temperature profile obtained by the simulations. Here we compare the temperatures of the desired top and bottom compositions (“optimal”) with the temperatures of

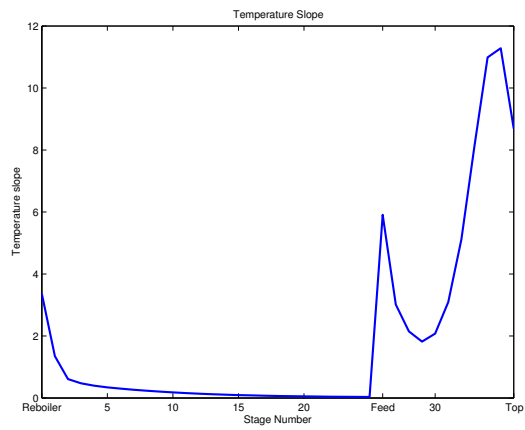

Figure 2: Temperature slope ($^{\circ}\text{C}$).

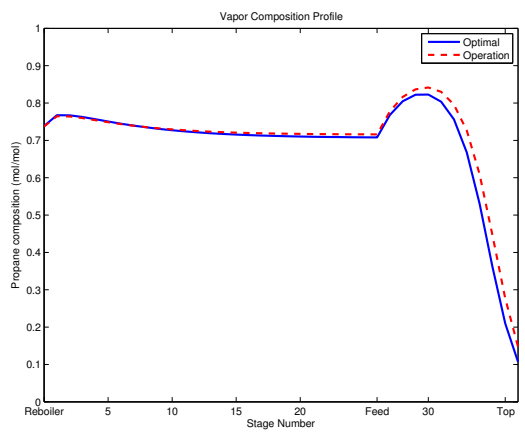

Figure 3: C_3 composition profile (mol/mol).

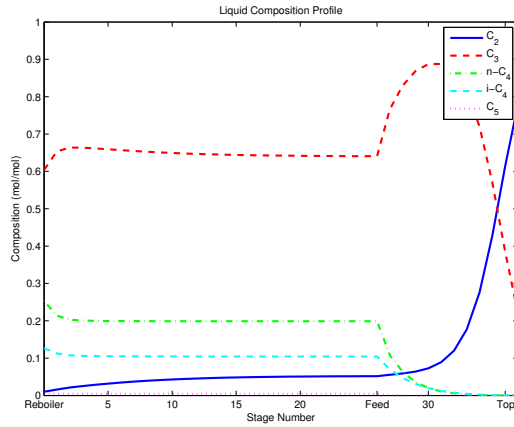

Figure 4: Composition profile (mol/mol).

the actual operational point (“operation”). We can see that there is a slight difference in the top temperature. The desired temperature should be around $-0.8\text{ }^{\circ}\text{C}$, but the column actually works at a bit higher temperature of around $+2.5\text{ }^{\circ}\text{C}$. The result is that the composition of C_3 obtained in the distillate flow rate (15%) is higher than the desired specification (maximum of 10%), see Figure 3.

The operational temperature in the reboiler should be higher than presented in the plot (around $75\text{ }^{\circ}\text{C}$), but ASPEN Plus was not able to converge at that temperature for the reboiler. The temperature that ASPEN reached was around 70°C (see Figure 1), which is the same temperature found in the “Process Flow Diagram” provided by Statoil.

We can see from Figure 1 that the temperature profile is very flat in the bottom section. It implies that the temperature slope (temperature difference between neighbouring stages) is very small (see Figure 2), so we shouldn’t control a temperature in this region (Hori and Skogestad, 2007b; Luyben, 2005). This happens because the initial (high frequency) gain, which corresponds to the desired closed-loop time constant, is of primary importance (Skogestad, 1997) and is directly proportional to the temperature difference. For dynamic control purpose it is better a large dynamic gain, and then good to control temperature at a stage where the slope is large (Hori and Skogestad, 2007b).

The compositions are also quite flat in the bottom section (see Figures 3 and 4).

The simulation results presented in Section 3 confirm that the best location for a temperature measurement is in the upper part of the column.

3 Control structures

In this section we will test several different control structures. Luyben (2004) cites some characteristics of columns with partial condensers that should be taken into consideration while choosing the control structure to be used:

- There is no effect of vapor flow rate on reflux drum level, so the distillate flow rate cannot be used to control directly the reflux drum level
- Besides the condenser duty, the pressure is affected by the distillate flow rate, resulting in interactions between the control loops that manipulate these two variables

- There is a strong interaction among the pressure, temperature and level loops, so the pairing and tuning of these loops are much more difficult than in a total-condenser column

The difference among the stabilizing control structures is how to control the top pressure and the reflux drum level. The only stabilizing loop that does not change is the bottom level control loop. The bottom level is always controlled by the bottom flow rate (B). Besides, the bottom flow rate and the reflux flow rate (L) are flow controlled, as is done by Statoil (see Figures 6 and 13).

For each one of these 6 stabilizing control structures, we will have 5 different ways to control the temperatures:

1. Open loop - in this structure, we keep both temperature control loops opened, i.e., we just close the pressure and level loops
2. Control temperature T36 (or T37 for structure 1)
3. Control temperature T4
4. Control the temperature with highest gain (usually tray 36). Structure 3 (see Section 3.3) is the only one where we are controlling tray 31. The main difference here from item 2 is the manipulated variable
5. Two point temperature control - in this structure we control temperatures T36 and T4

So, it means that we have, in total, 30 different control structures (including pressure, level and temperature loops).

We decided to control the temperatures in trays 4 and 36 (temperature 37 for structure 1) because these temperatures have been controlled in the normal operation of the column (see Figures 6 and 13).

For the simulations presented below, we applied a disturbance in the feed flow rate (valve opening change from 50% to 55%) at time $t = 0$. We also included noise and bias in all measurements. Another important disturbance that should be considered is the feed composition.

3.1 Stabilizing control structure 1

The first control structure is shown in Figure 5. In this structure, we used the following control loops to stabilize the column, i.e., to control pressure and top and bottom levels:

- the bottom level is controlled by the bottom flow rate B , which is flow controlled
- the pressure is controlled by the distillate flow rate D
- the reflux drum level is controlled by the reflux flow rate L , which is flow controlled

This stabilizing control structure has been used by Statoil (see Figure 6) to control the deethanizer.

The problem with this control structure is that the distillate flow rate (vapor product) is very small compared to the bottom product and the feed (about 1% of the total feed). In this case, this flow can easily saturate (see Figure 7), so it shouldn't be used for pressure control, at least without closing a temperature loop. This can be explained in the following example: suppose we have an increase in the feed flow rate, the pressure will decrease and the pressure controller will close the distillate flow rate. As this the distillate is small, it will probably saturate, i.e., the pressure will steadily decrease. On the other hand, if we have a temperature loop closed, the increase in the feed

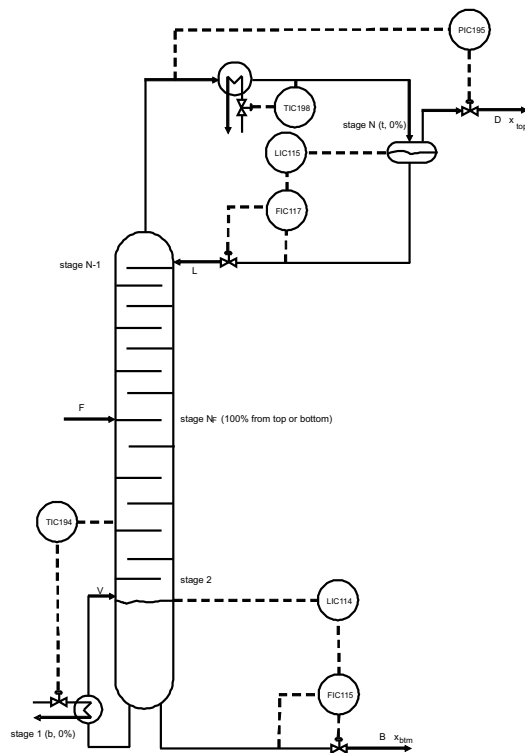

Figure 5: Stabilizing control structure 1: VV_T configuration.

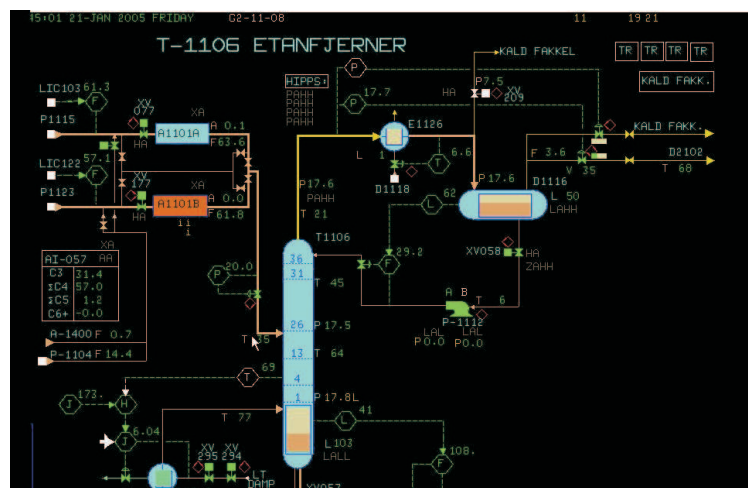

Figure 6: Stabilizing control structure 1 - Operation screen from Mongstad/Statoil (21/01/2005).

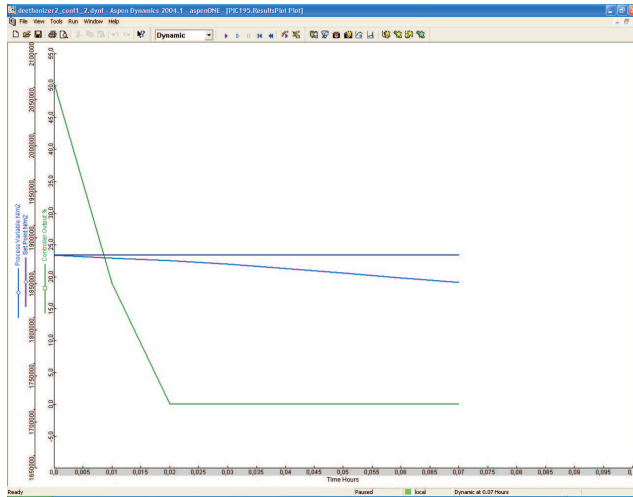

Figure 7: With a 5% change in valve V1, the distillate flow rate (vapor product) stream saturates.

flow rate will decrease the column temperature and the controller will increase the vapor flow rate (if we manipulate the reboiler duty), increasing the pressure again. This conclusion is confirmed by Figures 9, 10, and 11) and by Luyben (2004).

As we have two degrees of freedom available (condenser duty (Q_c) and reboiler duty (Q_b)), we decided to control two temperatures to improve the system response.

So, after adding the temperature loops, we considered the following three control structures:

1. Q_c -T37: manipulate the condenser duty (Q_c) to control the temperature of the condenser output, keeping the second temperature loop opened
2. Q_b -T4: manipulate the reboiler duty (Q_b) to control the temperature in tray 4, keeping the other temperature loop opened
3. Q_b -T36: manipulate the reboiler duty (Q_b) to control the tray which has the highest gain (most sensitive tray), keeping the other temperature loop opened

Here we didn't include the two-point temperature control (closing both temperature loops Q_c -T37 and Q_b -T4) because its response was too poor. By the same reason, we excluded the open loop approach (keeping both temperature loops opened).

To choose the most sensitive tray, we applied a step change in the reboiler duty (Q_b), see Figure 8. In this figure we just show the response for the temperatures that are measured in the real column (bottom, trays 4, 13, 31, 36 and condenser output). As can be seen, the temperature with highest gain (most sensitive) is in tray 36. It means that, according to Hori and Skogestad (2007b), this temperature is the best to be controlled. It is possible to see also that the temperatures in the bottom section are very low sensitive, i.e., they shouldn't be used for control (Hori and Skogestad, 2007a). This result confirms that we shouldn't control a temperature where we have small temperature slope (temperature change from tray to tray) is small (Luyben, 2005), i.e., where the temperature profile is flat (see Section 2).

The control structures are compared in Figure 9 for a disturbance in feed flow rate. In this plot, we compare the indirect control of the top and bottom compositions, i.e., we check how much the

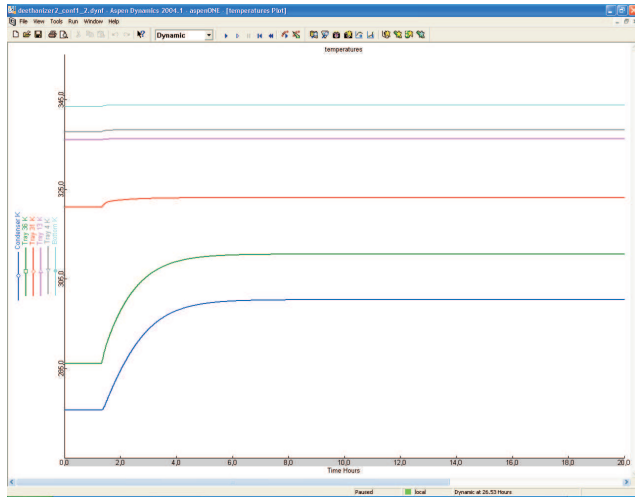

Figure 8: Stabilizing control structure 1 - Step test to choose the most sensitive temperature.

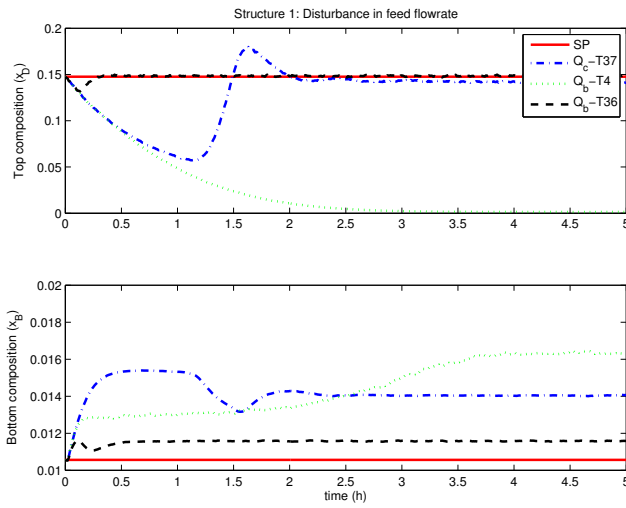

Figure 9: Stabilizing control structure 1 - Composition response.

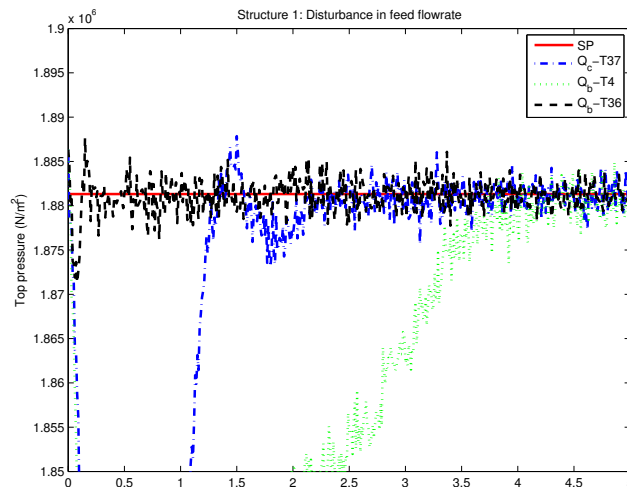

Figure 10: Stabilizing control structure 1 - Pressure.

top and bottom compositions deviate from their desired setpoints in the presence of disturbances and implementation error (noise and bias). The objective is to choose the control structure that gives the smallest composition deviation (smallest “loss”). From this figure, it is possible to see that the best structure is Q_b -T36. This structure gives almost zero deviation for top composition and the smallest for bottom composition. This result confirms that, in this case, it is better to control a temperature in the top section (highest gain and large temperature slope). Although it can seem a bit strange to control a temperature in the top section manipulating the reboiler duty (Q_b), Hori and Skogestad (2007b) present some examples of columns that have this same characteristic.

The problem in using control structure 1 is that it strongly depends on the temperature loop, otherwise it can have problems to control the pressure (Figure 7). As temperature controllers usually do not have problems, than this control structure is a good choice. This result shows that the common heuristics of not using a small flow to stabilize a column does not work when we close the temperature loops.

Figure 10 shows the performances of the top pressure control for the control structures studied in this section. The plot shows that just structure Q_b -T36 is able to give a good control of the top pressure, while structures Q_c -T37 and Q_b -T4 result in poor control. This result confirms that structure Q_b -T36 is the best choice for control structure 1.

Figure 11 presents the control of both levels (reflux drum and bottom levels). As can be seen here, all structures (Q_c -T37, Q_b -T36, and Q_c -T4) are able to control the reflux drum level. On the other hand, the control of the bottom level is good for Q_b -T36 and Q_b -T4 but very poor for Q_c -T37. It is possible to verify in the control of the bottom level that, differently from the reflux drum level controller, the bottom level controller does not reach the set point for none of the structures (results in off-set). This off-set is caused by the bias used here, i.e., we can see that the reflux drum level controller is able to handle bias better than the bottom level controller. Although an off-set is undesirable, in this case it does not cause any problem in the process because the level does not affect the steady-state.

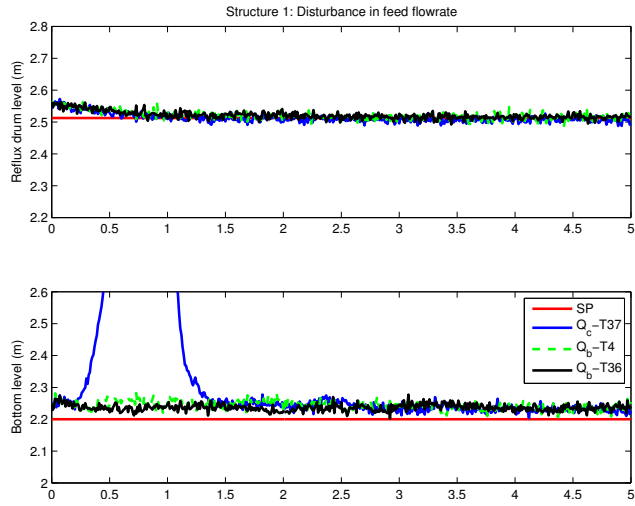

Figure 11: Stabilizing control structure 1 - Level.

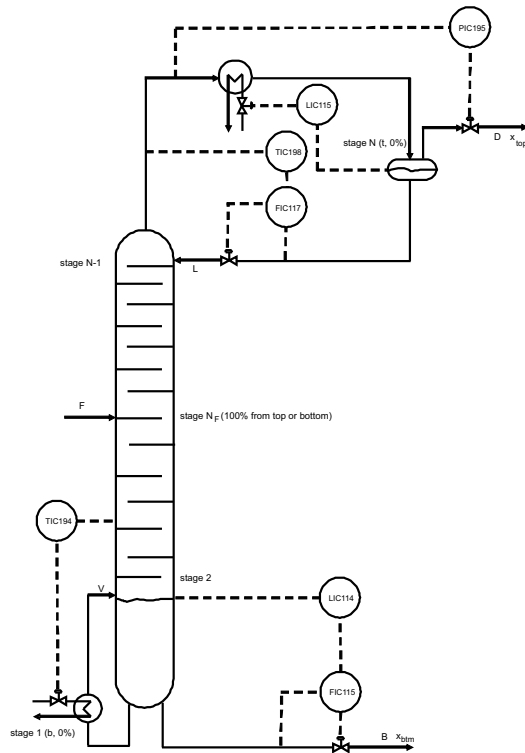

Figure 12: Stabilizing control structure 2: LV configuration.

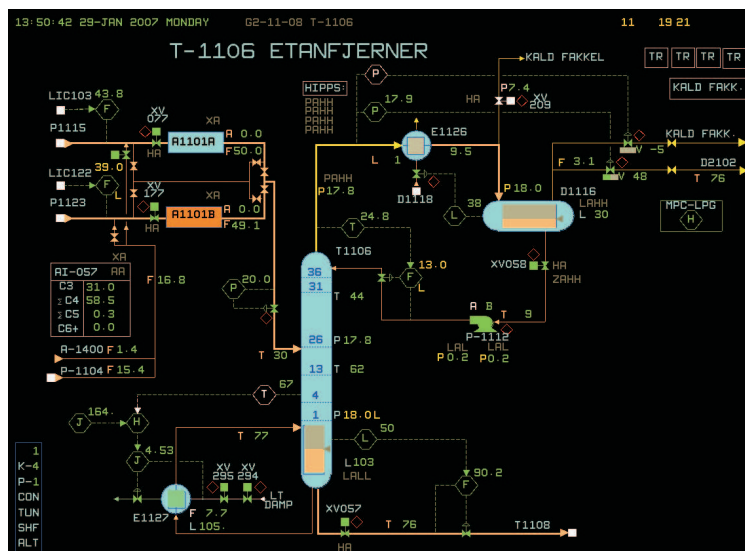

Figure 13: Stabilizing control structure 2 - Operation screen from Mongstad/Statoil (29/01/2007).

3.2 Stabilizing control structure 2

The second control structure is shown by Figure 12, where the stabilizing control loops (pressure and level loops) are:

- the bottom level is controlled by bottom flow rate B , which is flow controlled
- the pressure is controlled by distillate flow rate D
- the reflux drum level is controlled by condenser duty Q_c
- the reflux flow rate L is flow controlled, i.e., it is kept constant

This stabilizing control structure has also been used by Statoil (see Figure 13) to control the deethanizer.

As this control structure also controls the top pressure manipulating the distillate flow rate D , it presents the same problem as control structure 1 (saturation in the distillate), see Figure 7 in Section 3.1. So, for this structure, it is also necessary to close at least one temperature controller.

In this stabilizing structure, the two available manipulated variables are the reflux flow rate and the reboiler duty.

The control structures derived from this stabilizing structure, after closing the temperature loops, are:

1. L -T36: manipulate the reflux flow rate to control the temperature in tray 36, keeping the second temperature control loop opened
2. Q_b -T4: manipulate the reboiler duty to control the temperature in tray 4, keeping the other temperature control loop opened
3. Q_b -T36: manipulate the reboiler duty to control the tray which has the highest gain (most sensitive tray), keeping the other temperature loop opened

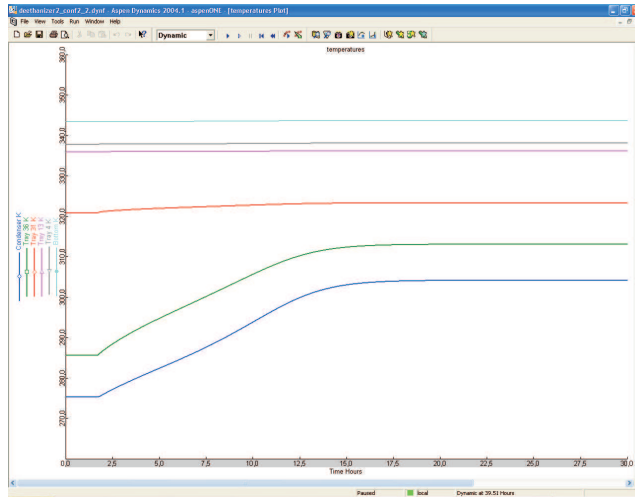

Figure 14: Stabilizing control structure 2 - Step test to choose the most sensitive temperature.

4. L -T36 and Q_b -T4: manipulate the reflux flow rate to control the temperature in tray 36 (L -T36) and manipulate the reboiler duty to control the temperature in tray 4 (Q_b -T4). This is the two-point temperature control strategy

As for structure 1 (see Section 3.1), we didn't include the open loop strategy (both temperature control loops opened) because its response was very poor.

The most sensitive temperature (tray with highest gain) was chosen applying a step change in the reboiler duty. Figure 14 shows that the most sensitive temperature is in tray 36, confirming that the bottom section is quite insensitive to the manipulated variables.

The control structures are compared in Figure 15, where we plot the top and bottom compositions. As we want to choose a control structure that minimizes the effect of disturbances and implementation error (noise and bias) in the top and bottom compositions (indirect control), we can see that the best control structure is Q_b -T36, confirming that, in this case, it is better to control a temperature in the top section. These results confirm that the two-point temperature control strategy (closing L -T36 and Q_b -T4) does not improve the control system for multicomponent columns (Hori and Skogestad, 2007b).

The problem in using control structure 2 is that it strongly depends on the temperature loop, as for structure 1.

Figure 16 compares the top pressure control response for the control structures analysed in this section. The pressure control using control structure L -T36 results in a poor performance, confirming that this structure it is not a good choice. The other structures (Q_b -T4, Q_b -T36, and two-point temperature control) result in good top pressure control.

Figure 17 compares the control performance of the reflux drum level and the bottom level. Again we can see that control structure L -T36 gives the worse response (at least for the bottom level). The control performance of the reflux drum level is good for all structures, been similar to the results obtained for control structure 1 (see Section 3.1).

The control of bottom level, on the other hand, is good for most structures (Q_b -T4, Q_b -T36, and two-point temperature control), except for control structure L -T36.

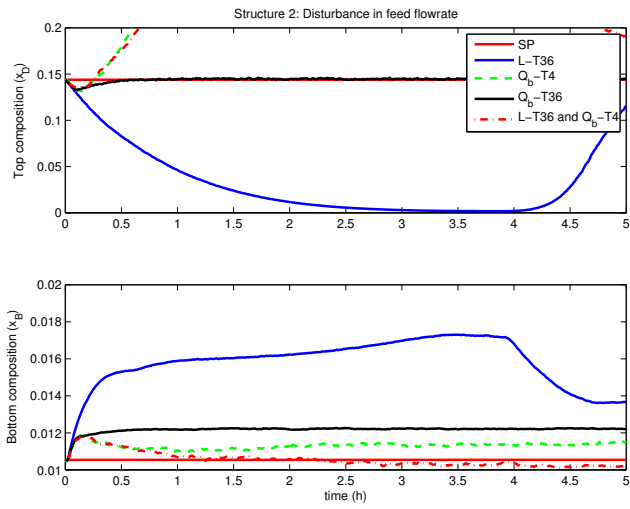

Figure 15: Stabilizing control structure 2 - Composition response.

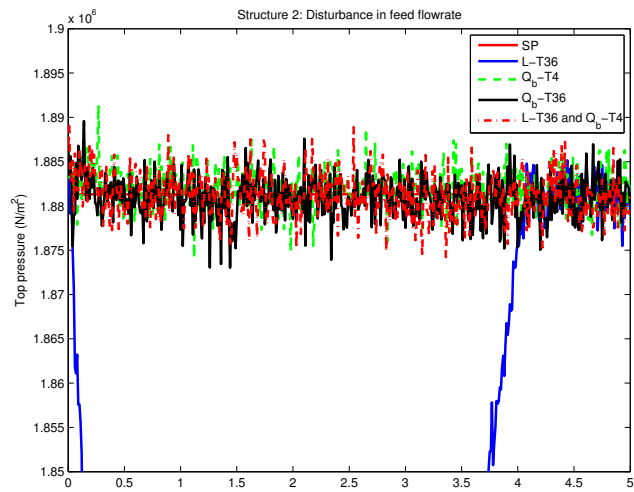

Figure 16: Stabilizing control structure 2 - Pressure.

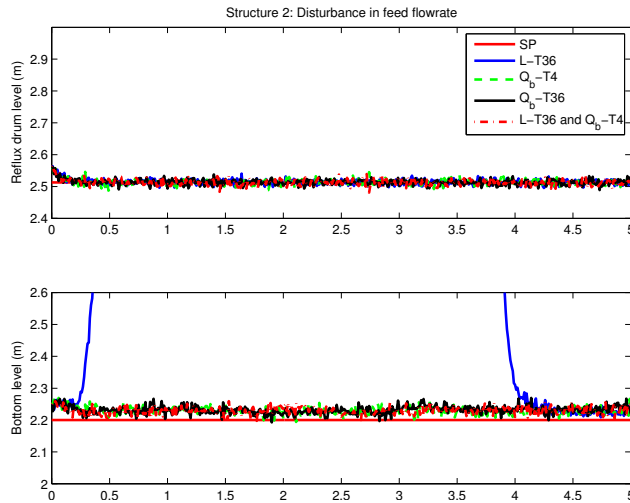

Figure 17: Stabilizing control structure 2 - Level.

3.3 Stabilizing control structure 3

Figure 18 shows the stabilizing control structure 3:

- the bottom level is controlled by the bottom flow rate B , which is flow controlled
- the pressure is controlled by the condenser duty Q_c
- the reflux drum level is controlled by the reflux flow rate L , which is flow controlled

This structure does not have the saturation problem that we found in the first two structures because the distillate flow rate is not used to control neither level nor pressure. So, supposing that the feed flowrate increases, the pressure will decrease and the control loop will decrease the condenser duty and, consequently, the pressure will increase again.

The available degrees of freedom here are the distillate flow rate and the reboiler duty.

So, the control structures, including temperature loops, considered were:

1. Open loop: here just the stabilizing control loops (pressure and levels) are close, i.e., the temperature control loops are kept opened
2. D -T36: manipulate the distillate flow rate to control the temperature in tray 36, keeping the second temperature control loop opened
3. Q_b -T4: manipulate the reboiler duty to control the temperature in tray 4, keeping the other temperature control loop opened
4. Q_b -T31: manipulate the reboiler duty to control the tray which has the highest gain (most sensitive), keeping the other temperature control loop opened. This is the only stabilizing control structure that has tray 31 as the most sensitive
5. D -T36 and Q_b -T4: manipulate the distillate flow rate to control the temperature in tray 36 (D -T36) and manipulate the reboiler duty to control the temperature in tray 4 (Q_b -T4). This is the two-point temperature control

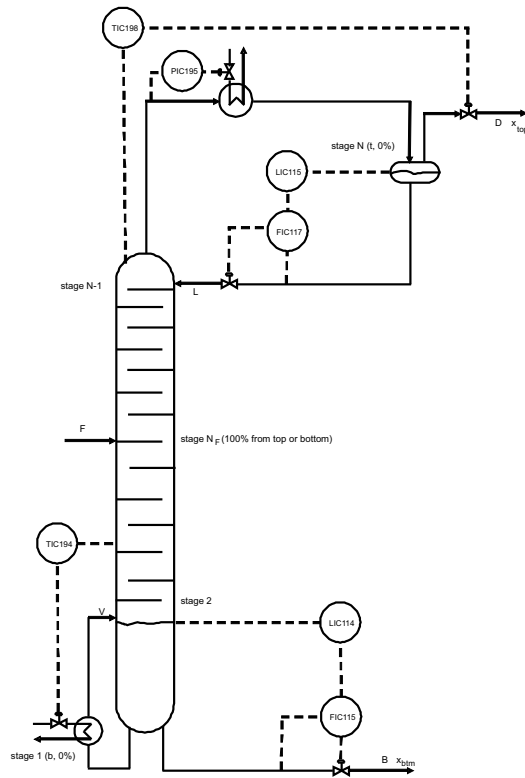

Figure 18: Stabilizing control structure 3: *DV* configuration.

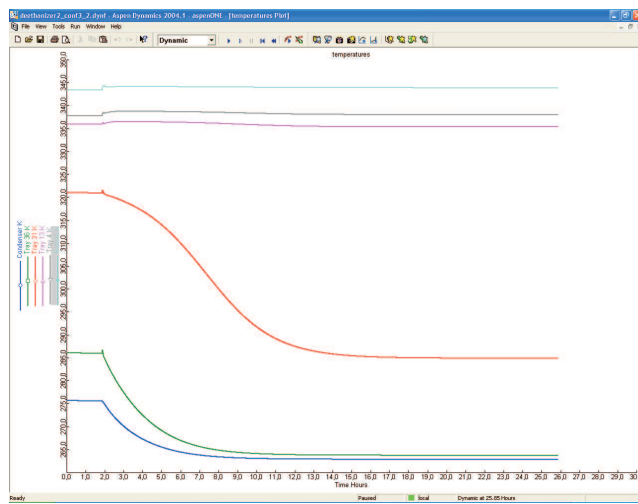

Figure 19: Stabilizing control structure 3 - Step test to choose the most sensitive temperature.

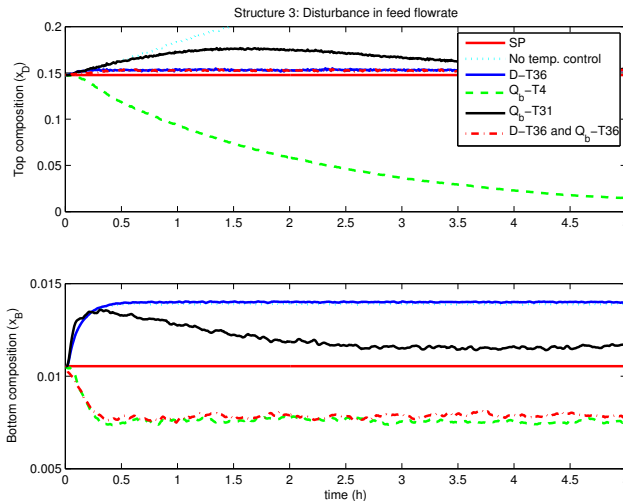

Figure 20: Stabilizing control structure 3 - Composition response.

In Figure 19 is presented a step test in the reboiler boilup to select the most sensitive tray temperature. As can be seen by the results, the temperatures in the top section are much more sensitive than the temperatures in the bottom, confirming the results obtained by the stabilizing control structures 1 (Section 3.1) and 2 (Section 3.1). Specifically for this stabilizing control structure, tray 31 is the most sensitive so we controlled the temperature of this tray manipulating the vapor boilup (Q_b -T31).

The simulations for stabilizing control structure 3 are presented in Figure 20, where we compare the different control structures studied in this section plotting the top and bottom compositions. It is possible to see that the control structure that gives the smallest composition deviation is Q_b -T31 (control the temperature in tray 31 manipulating the reboiler duty). This result is very similar to the previous stabilizing structures.

Figure 21 compares the performance of the control structures studied to control the top pressure. For this stabilizing control structure, all control structures are able to control the top pressure confirming that the pressure control is not a problem for this structure, differently from structures 1 (Section 3.1) and 2 (Section 3.2). This happens because here we are using the condenser duty for pressure control, instead of using the distillate flow rate.

The performances of the control structures to control the reflux drum level and the bottom level are presented in Figure 22. Control structures D -T36 and Q_b -T31 are able to control well the reflux drum level, but control structures Q_b -T4 and the two-point temperature control result in poor control.

The control of bottom level, on the other hand, is good for all structures.

3.4 Stabilizing control structure 4

The fourth stabilizing control structure is shown by Figure 23:

- the bottom level is controlled by the bottom flow rate, which is flow controlled
- the pressure is controlled by the reboiler duty

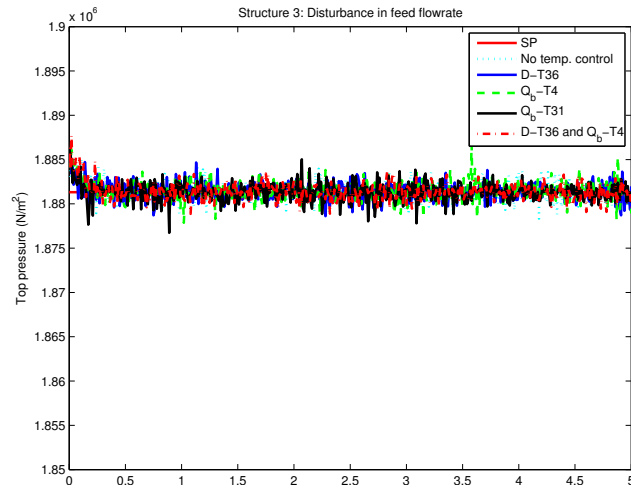

Figure 21: Stabilizing control structure 3 - Pressure.

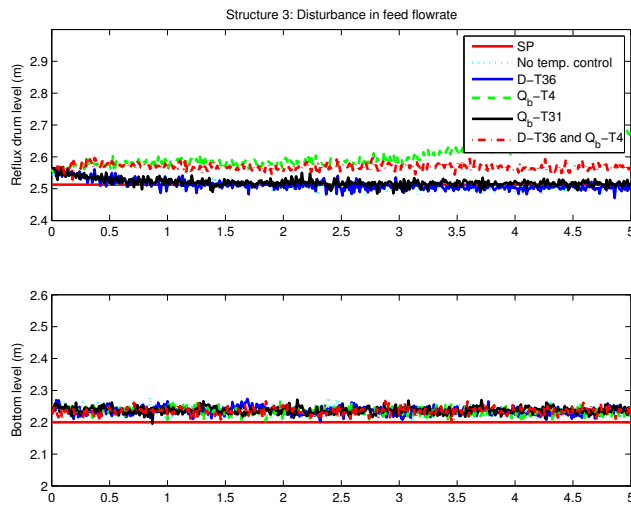

Figure 22: Stabilizing control structure 3 - Level.

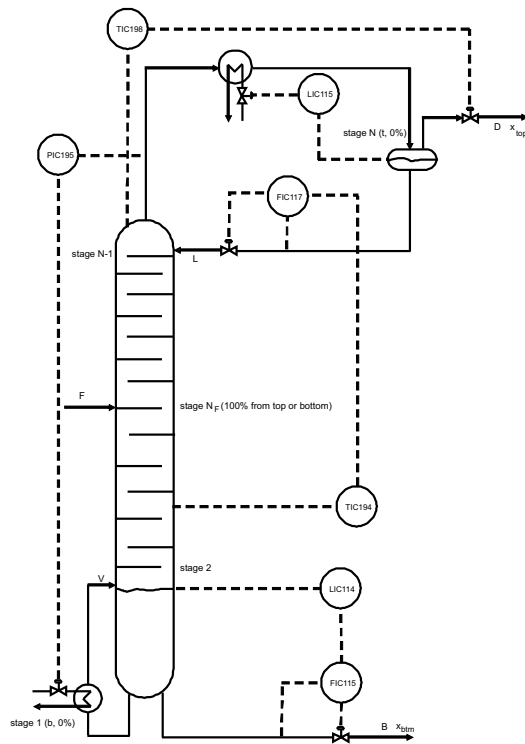

Figure 23: Stabilizing control structure 4: *LD* configuration.

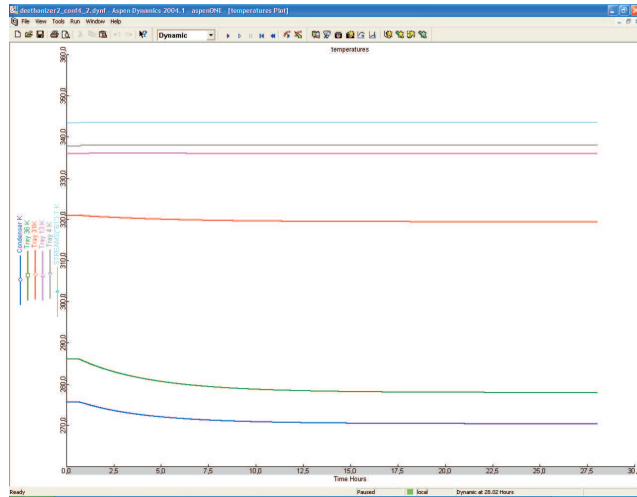

Figure 24: Stabilizing control structure 4 - Step test to choose the most sensitive temperature.

- the reflux drum level is controlled by the condenser duty
- the reflux flow rate is flow controlled

As for structure 3 (see Section 3.3), this structure also does not present saturation problem because it does not use the distillate flow rate to control the levels neither the pressure. So, supposing that the feed flow rate increases, the pressure will decrease and the pressure control loop will increase the vapor flow rate and, consequently, the pressure will increase again.

The available degrees of freedom here are distillate flow rate and reflux flow rate. So, the control structures considered were:

1. Open loop: here just the stabilizing control loops (pressure and levels) are closed, i.e., the temperature control loops are kept opened
2. *D-T36*: manipulate the distillate flow rate to control the temperature in tray 36, keeping the second temperature control loop opened
3. *L-T4*: manipulate the reflux flow rate to control the temperature in tray 4, keeping the other temperature control loop opened
4. *L-T36*: manipulate the reflux flow rate to control the tray which has the highest gain (most sensitive), keeping the other temperature control loop opened
5. *D-T36* and *L-T4*: manipulate the distillate flow rate to control the temperature in tray 36 (*D-T36*) and manipulate the reflux flow rate to control the temperature in tray 4 (*L-T4*). This is the two-point temperature control

In Figure 24 is presented a step test in the reflux rate to select the most sensitive tray temperature. As can be seen by the results, the temperatures in the top section are much more sensitive than the temperatures in the bottom. Specifically for this case, tray 36 is the most sensitive so we controlled the temperature of this tray manipulating the reflux flow rate.

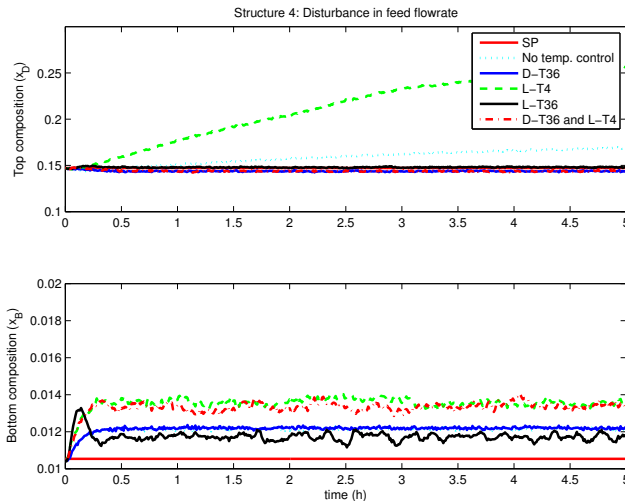

Figure 25: Stabilizing control structure 4 - Composition response.

The simulations for the stabilizing control structure 4 are presented in Figure 25, where we compare the control performances of the control structures studied plotting the top and bottom compositions (indirect control in the presence of disturbances and implementation error). In this case, we can see that the best choice is to control the temperature in tray 36 manipulating the distillate flow rate (D -T36) or the reflux flow rate (D -T36). Again, the control of a temperature in the bottom section does not give a good indirect control of the top and bottom compositions. The two-point temperature control also does not improve the control performance.

Figure 26 compares the control performances of the control structures studied for controlling the top pressure. In this plot, we can see that all control structures are able to control the top pressure confirming that the pressure control is not a problem for this structure, differently from structures 1 (Section 3.1) and 2 (Section 3.2). This happens because here we are using the reboiler duty for pressure control, instead of using the distillate flow rate. This result is similar to structure 3 (Section 3.3).

In Figure 27, we present the control of the reflux drum level and the bottom level. For stabilizing control structure 4, all control structures are able to control both levels.

3.5 Stabilizing control structure 5

The fifth stabilizing control structure, shown by Figure 28, is very similar to configuration 4. The only difference is that we keep D (distillate flow rate) and L/D (reflux over distillate flow rates) constant. The stabilizing control loops are:

- the bottom level is controlled by the bottom flow rate, which is flow controlled
- the pressure is controlled by the reboiler duty
- the reflux drum level is controlled by the condenser duty
- the reflux flow rate is flow controlled
- manipulate the reflux flow rate (L) to keep L/D constant

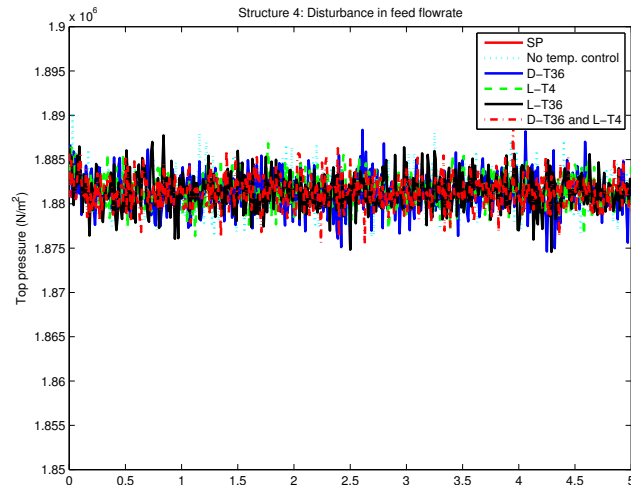

Figure 26: Stabilizing control structure 4 - Pressure.

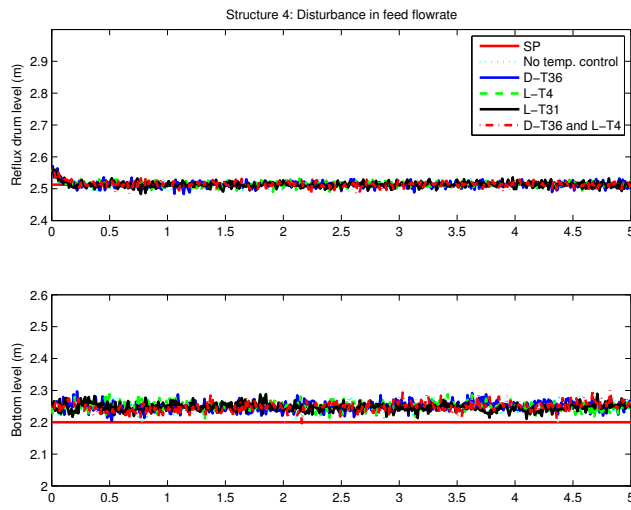

Figure 27: Stabilizing control structure 4 - Level.

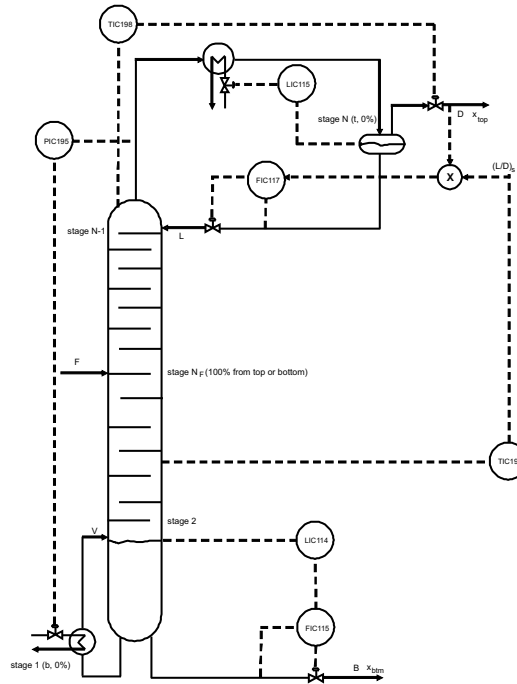

Figure 28: Stabilizing control structure 5: $D - L/D$ configuration.

For the same reason as for structures 3 and 4 (it does not use distillate flow rate to control pressure and level), this structure also does not present saturation problem.

The available degrees of freedom here are distillate flow rate and ratio between reflux (L) and distillate (D) flow rates.

So, the structures considered were:

1. Open loop: here just the stabilizing control loops (pressure and levels) are close, i.e., the temperature control loops are kept opened
2. D -T36: manipulate the distillate flow rate to control the temperature in tray 36, keeping the second loop opened
3. L/D -T4: manipulate the ratio to control the temperature in tray 4, keeping the other loop opened
4. L/D -T36: manipulate the ratio to control the tray which has the highest gain (most sensitive), keeping the other loop opened
5. D -T36 and L/D -T4: manipulate the distillate flow rate to control the temperature in tray 36 (D -T36) and manipulate the ratio to control the temperature in tray 4 (L/D -T4)

In Figure 29 is presented a step test in the reflux rate to select the most sensitive tray temperature (tray with highest gain). As can be seen by the results, the temperatures in the top section are much more sensitive than the temperatures in the bottom. Specifically for this case, tray 36 is the most sensitive so we controlled the temperature of this tray manipulating the ratio between the reflux and distillate flow rates (L/D).

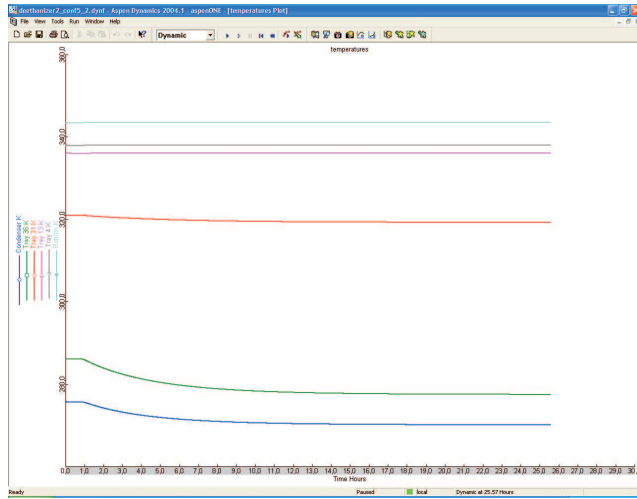

Figure 29: Stabilizing control structure 5 - Step test to choose the most sensitive temperature.

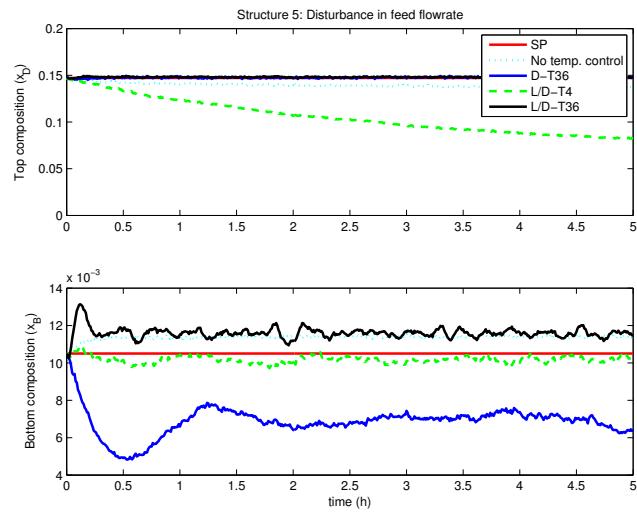

Figure 30: Stabilizing control structure 5 - Composition response.

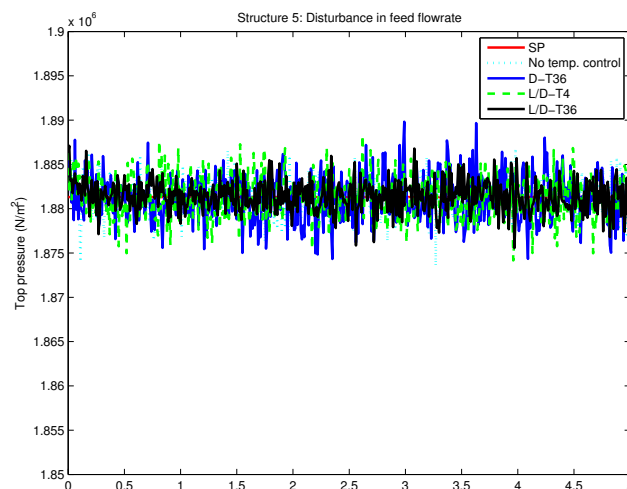

Figure 31: Stabilizing control structure 5 - Pressure.

The simulations for stabilizing control structure 5 are presented in Figure 30, where we plot the top and bottom compositions to compare the performance of the control structures studied for indirect composition control in the presence of disturbances and implementation errors (noise and bias). As we can see that the best choice is to use an open-loop approach, i.e., keep both temperature controllers opened or control. This result is quite surprising because none of the other stabilizing control structures studied gave a result like this.

Another control structure that gave a good result is to control the temperature in tray 36 manipulating the reflux flow rate. The simulation for two temperatures is not presented due to very poor response.

Figure 31 presents the top pressure control for stabilizing control structure 5. In this plot, we compare the performances of the control structures studied for pressure control. Here we can see that all control structures are able to control the top pressure confirming that the pressure control is not a problem for this structure, differently from structures 1 (Section 3.1) and 2 (Section 3.2). This happens because here we are using the reboiler duty for pressure control (like structure 4, see Section 3.4), instead of using the distillate flow rate. This result is similar to structures 3 (Section 3.3) and 4.

In Figure 32, we present the control of reflux drum level and bottom level. For stabilizing control structure 5, all structures are able to control both levels.

Structures 4 (see Section 3.4) and 5 are the only ones that didn't have any problem to control neither pressure nor levels.

3.6 Stabilizing control structure 6

The sixth stabilizing control structure is shown by Figure 33:

- the bottom level is controlled by bottom flow rate, which is flow controlled
- the pressure is controlled by condenser duty
- the reflux drum level is controlled by distillate flow rate

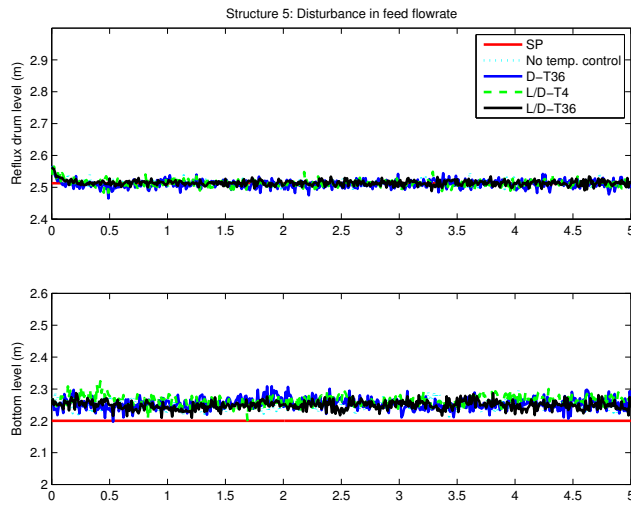

Figure 32: Stabilizing control structure 5 - Level.

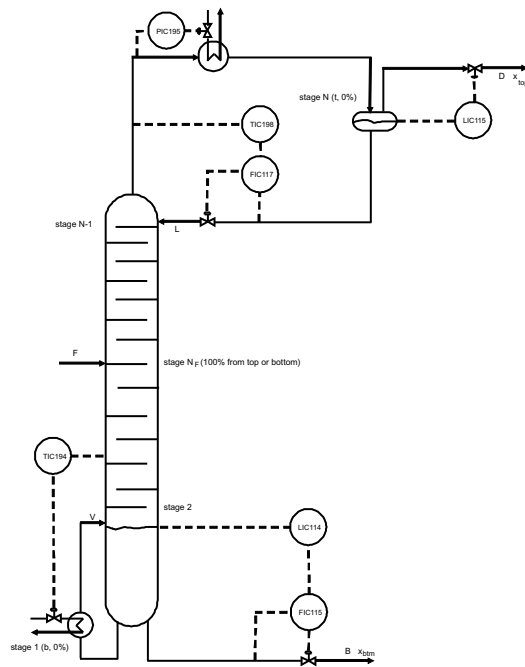

Figure 33: Stabilizing control structure 6: *LV* configuration.

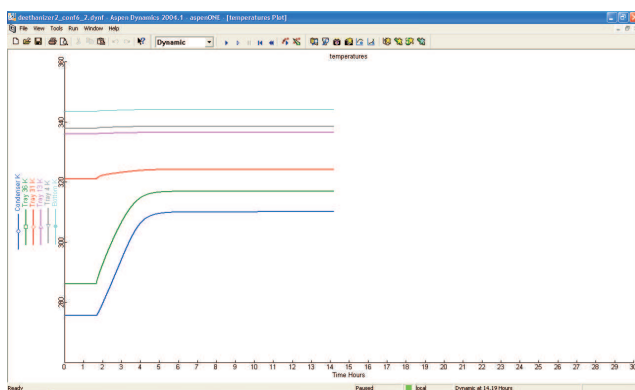

Figure 34: Stabilizing control structure 6 - Step test to choose the most sensitive temperature.

- the reflux flow rate is flow controlled

The problem of this structure is its dependence on the temperature control loop. It happens because we use the distillate flow rate to control the reflux drum level. If the the temperature loop fails, the system becomes unstable. This happens because the distillate flow rate (D) does not have direct effect in the reflux drum level, confirming that it cannot be directly used to control reflux drum level (Luyben, 2004).

The available degrees of freedom here are reflux flow rate and reboiler duty. So, the control structures considered are:

1. L -T36: manipulate the reflux flow rate to control the temperature in tray 36, keeping the second temperature control loop opened
2. Q_b -T4: manipulate the reboiler duty to control the temperature in tray 4, keeping the other temperature control loop opened
3. Q_b -T36: manipulate the reboiler duty to control the tray which has the highest gain (most sensitive), keeping the other temperature control loop opened
4. L -T36 and Q_b -T4: manipulate the reflux flow rate to control the temperature in tray 36 (L -T36) and manipulate the reboiler duty to control the temperature in tray 4 (Q_b -T4). This is the two-point temperature control

In Figure 34 is presented a step test in the reflux rate to select the most sensitive tray temperature. As can be seen by the results, the temperatures in the top section are much more sensitive than the temperatures in the bottom, confirming the results from all previous stabilizing control structures. Specifically for this case, tray 36 is the most sensitive so we controlled the temperature of this tray manipulating the reflux flow rate.

The simulations for structure 6 are presented in Figure 35, where we compare the performance of the control structures plotting the top and bottom compositions. As we can see, the control structure that gives the smallest indirect control composition deviation in the presence of disturbances and implementation errors (noise and bias) is Q_b -T36, where we control the temperature in tray 36 manipulating the reboiler duty. The simulation for open loop strategy (with temperature loops opened) is not presented due to very poor response.

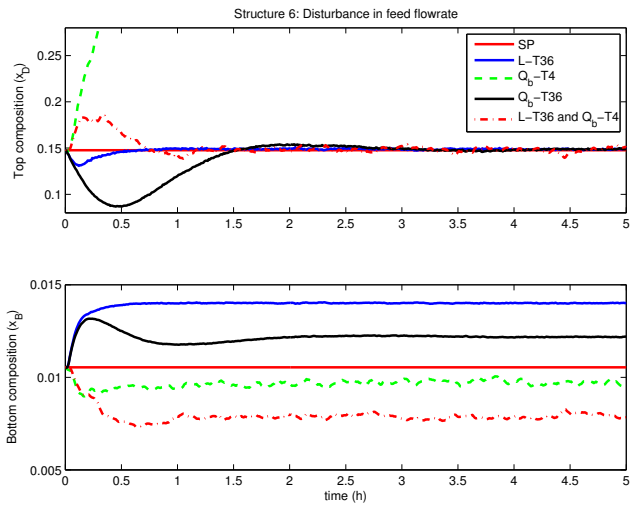

Figure 35: Stabilizing control structure 6 - Composition response.

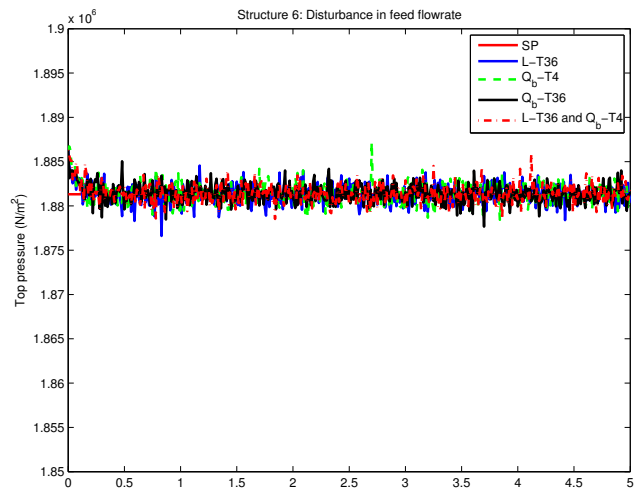

Figure 36: Stabilizing control structure 6 - Pressure.

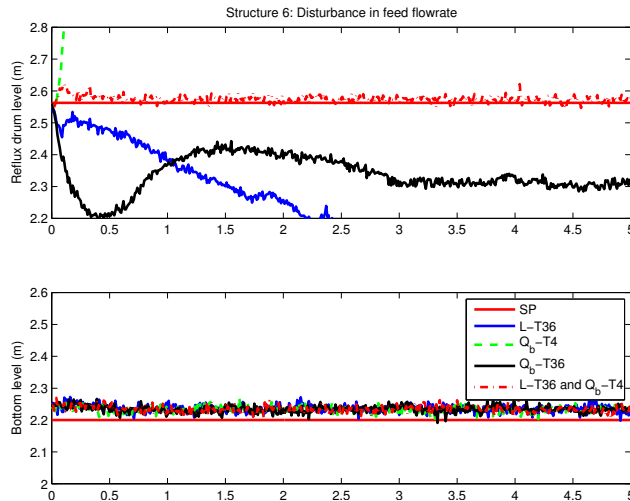

Figure 37: Stabilizing control structure 6 - Level.

Figure 36 shows the performance of the control structures studied to control the top pressure. Here we can see that all control structures are able to control the top pressure confirming that the pressure control is not a problem for this structure, differently from structures 1 (Section 3.1) and 2 (Section 3.2). This happens because here we are using the condenser duty for pressure control (like structure 3, see Section 3.3), instead of using the distillate flow rate. This result is similar to structures 3, 4 (Section 3.4), and 5 (Section 3.5).

In Figure 37, we present the control of reflux drum level and bottom level. The only structure that shows a good control of the reflux drum is the two-point temperature control. Structures L -T36 and Q_b -T36 give reasonable results and Q_b -T4 is very poor. This result confirms that, as there is no effect of vapor flow rate on reflux drum level, distillate flow rate cannot be directly used to control reflux drum level (Luyben, 2004).

The control of bottom level, on the other hand, is good for all structures.

3.7 Comparing the best structures

In this section we will compare the best choice of each stabilizing control structure (1, 2, 3, 4, 5, and 6). The control structures selected are:

1. Stabilizing control structure 1 (Section 3.1): manipulate the reboiler duty to control the tray which has the highest gain (most sensitive), keeping the other temperature control loop opened (Q_b -T36)
2. Stabilizing control structure 2 (Section 3.2): manipulate the reboiler duty to control the tray which has the highest gain (most sensitive), keeping the other temperature control loop opened (Q_b -T36)
3. Stabilizing control structure 3 (Section 3.3): manipulate the reboiler duty to control the tray which has the highest gain (most sensitive), keeping the other temperature control loop opened (Q_b -T31)

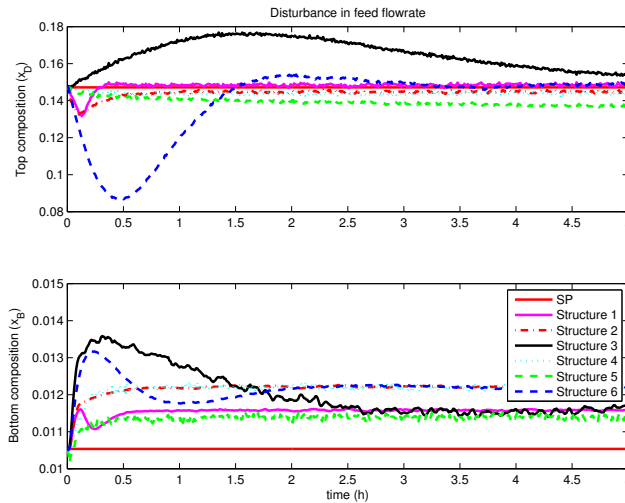

Figure 38: Comparing different control structures: Composition response.

4. Stabilizing control structure 4 (Section 3.4): manipulate the distillate flow rate to control the temperature in tray 36, keeping the second temperature control loop opened (D -T36)
5. Stabilizing control structure 5 (Section 3.5): use the open loop approach, i.e., keep both temperature controllers opened and closing just the stabilizing controllers for pressure and levels
6. Stabilizing control structure 6 (Section 3.6): manipulate the reboiler duty to control the tray which has the highest gain (most sensitive), keeping the other temperature control loop opened (Q_b -T36)

As can be seen, for most stabilizing control structures, the best control strategy is to control a temperature in the top section manipulating the reboiler duty.

Figure 38 compares the control structures above plotting the top and bottom compositions. The control structures that give the best indirect control composition (minimizes the composition deviation in the presence of disturbances and implementation errors) are stabilizing control structures 1 and 5. Also, structure 3 gives a reasonable response in steady state, but its dynamic response is too slow.

The problem in structure 1 is its dependence on the temperature controller which must be working well the whole time, otherwise it can have difficulties to control the pressure (see Figure 7).

For structure 5, the problem is that its performance is very dependent on the distillate flow rate measurement error. If this measurement is not accurate enough, its results can be very poor.

We can also verify from the results that the control of two temperatures is not optimum for this column. This confirms the results from Hori and Skogestad (2007b), which concluded that the control of two temperatures does not give any improvement for multicomponent columns.

It is important to note that these conclusions apply for a disturbance in feed flow rate. The same study should be done for disturbance in feed composition.

Figure 39 compares the pressure control for the selected control structures. We can see that the pressure control is good for all structures.

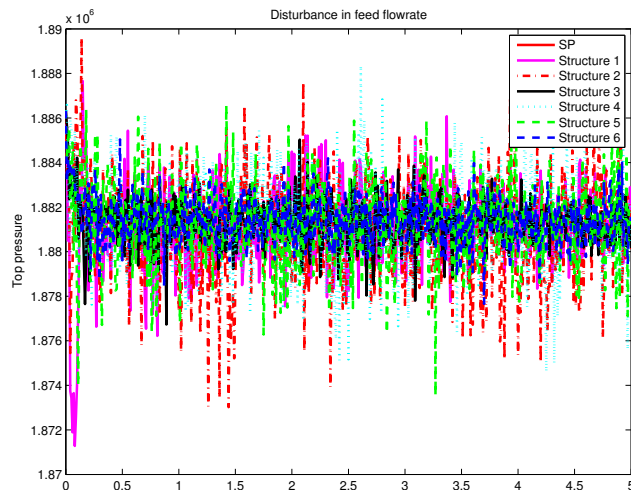

Figure 39: Comparing different control structures: Pressure.

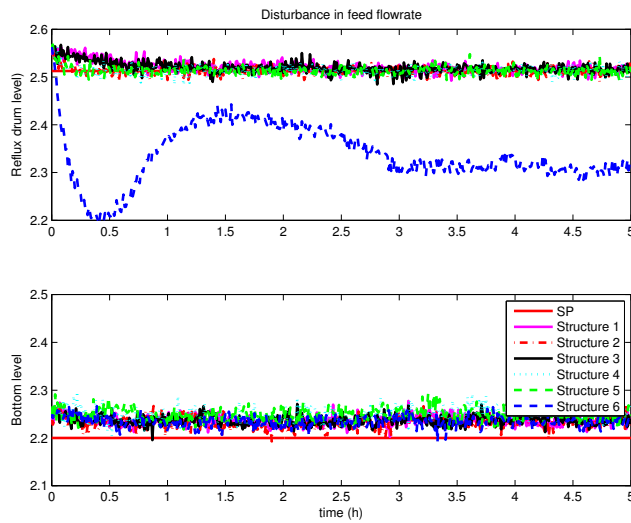

Figure 40: Comparing different control structures: Level.

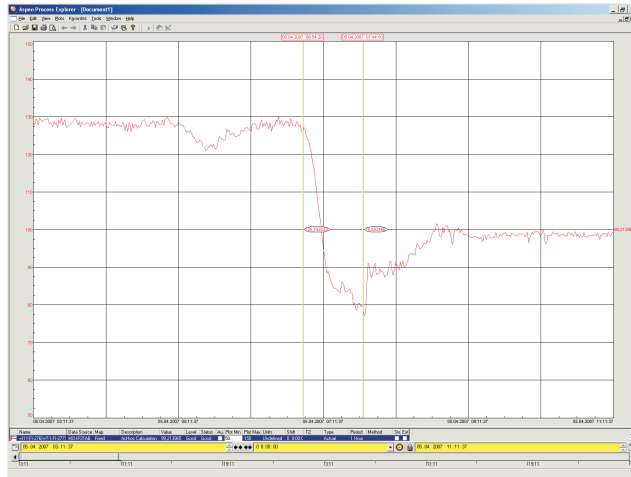

Figure 41: Mongstad: change in feed flow rate

The same comparison was done for both levels (reflux drum and bottom) in Figure 40. We can see that all structures are similar in the bottom level control, but control structure 6 fails to control the reflux drum level, as already seen in Section 3.6. This result confirms that structure 6 is the worst choice among the structures studied.

4 Large feed disturbance

In this section, we compare the structures selected in Section 3.7 with an even larger feed disturbance. In the normal operation of the plant, it is normal to have large changes in the feed flow rate due to difficulties in keeping the feed rate stable in the previous unit. The decrease is usually faster than the increase, since the decrease often is a cause of a trip and increase is when they start up again in a controlled way. Figure 41 shows an 8-hour plot where we can see that the feed drops 45 T/h in 50 minutes.

To compare the performance of the control structures selected in the previous section (Section 3), we will apply ramp disturbances in the feed flow rate from 150 t/h to 75 t/h in a 2-hour interval (from $t = 1h$ to $t = 3h$) and another ramp change from 75 t/h to 150 t/h in a 5-hour interval (from $t = 6h$ to $t = 11h$). Figure 42 presents the feed flow rate used in the simulation.

As structure 6 gave the worst result in the previous section, it was not included in the plots because, as already expected, its results didn't give good results.

4.1 Without ratio to feed

First, we will simulate the control structures selected in Section 3 without any ratio to feed. Figure 43 presents the response of the 5 control structures to the feed disturbance. For the top composition (up), the best performance is given by structure 4, but structures 1 and 2 also give good performances. On the other hand, structures 3 and 5 are not able to control the top composition.

For the control of the bottom composition, we can see that structure 3 gives the worst result. It happens because this structure is not able to control the pressure neither the levels due to saturation

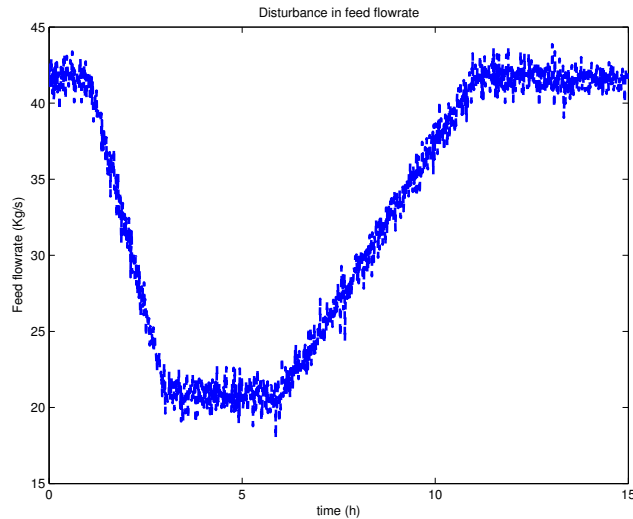

Figure 42: Feed flow rate

(see Figures 44 and 45). None of the structures were able to keep the bottom composition at the set point. This result was already expected due to the large disturbance. As all structures have at least one manipulated variable kept constant, one solution for this would be to rate the available manipulated with the feed flow rate. For example, for structure 1 we have the condenser duty available, so we could keep the rate between the feed flow rate and the cooling flow rate. This will be presented in Section 4.2.

Figure 44 presents the top pressure response to the feed disturbances. All structures but structure 1 were able to control the pressure, confirming that the pressure control is not a problem in this process.

Figure 45 presents the reflux drum and bottom levels. We can see that structure 3 is not able to control neither the reflux drum level nor the bottom level. All the other structures are able to control both levels at least reasonably.

4.2 Including ratio to feed

In this section, we will include ratios to feed to improve the performance of the control system in the presence of the large feed disturbance shown in Figure 41.

The ratios that we keep constant for each control structure are:

1. Control structure 1: keep Q_c/F constant
2. Control structure 2: keep L/F constant
3. Control structure 3: keep D/F constant
4. Control structure 4: keep L/F constant
5. Control structure 5: keep D/F constant

In the first control structure, we decided to keep Q_c/F constant because we are not able to manipulate the cooling stream flow rate in the condenser (the condenser duty is manipulated directly

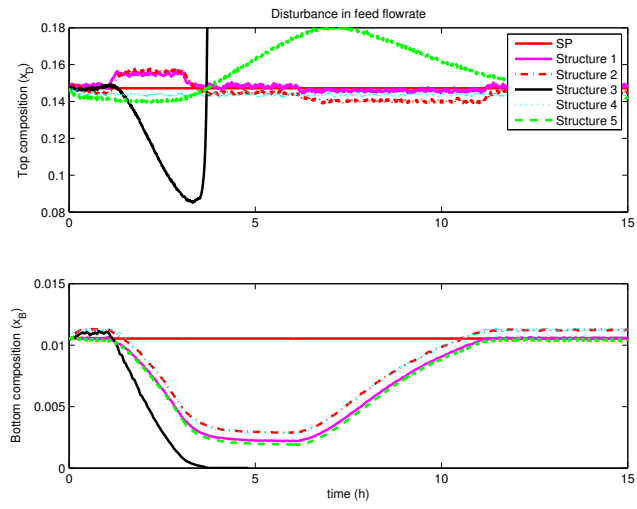

Figure 43: Ramp in feed flow rate: top and bottom compositions.

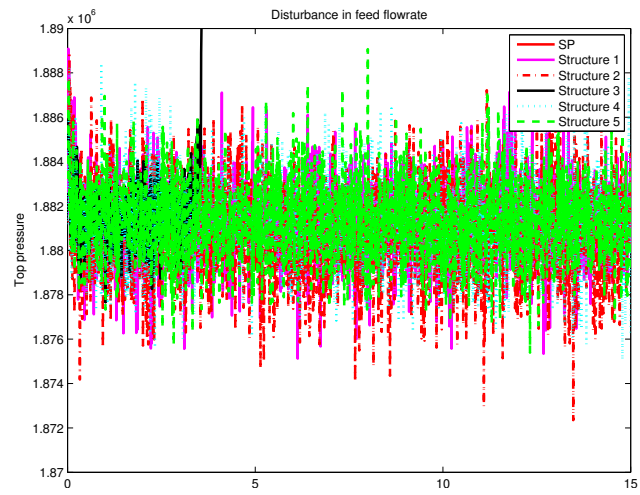

Figure 44: Ramp in feed flow rate: pressure.

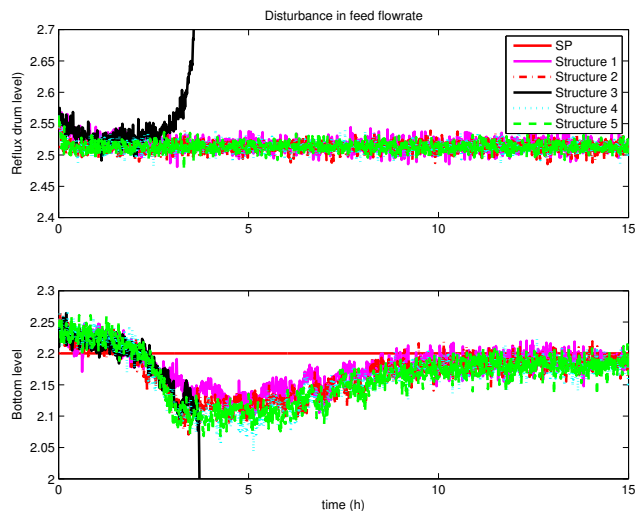

Figure 45: Ramp in feed flow rate: level.

in the ASPEN model used). Fortunately, this does not change the conclusions that we take in this report.

Figure 46 shows the performance of the control structures in the presence of disturbance. We can see, as already expected, that the presence of ratio controllers improved the control of the bottom composition for all structures (compare with Figure 43). Structure 3 has the worst result, so it should not be considered for control. While structure 4 gave the best control of the top composition, structure 1 has the best performance for the bottom.

Figure 47 presents the top pressure response to the feed disturbances. All structures were able to control the pressure, confirming that the pressure control is not a problem in this process.

Figure 48 shows the level control plots. Except for structure 3, all the other structures are able to control the reflux drum level. For the bottom level, all structures are able to keep it stable.

5 Conclusions

In this work we compared several different control structures of the deethanizer from Mongstad/Statoil. The main conclusions here are:

1. We shouldn't control a temperature in the bottom section because its trays are quite insensitive to the manipulated variables. This confirms that we shouldn't control a temperature where the temperature slope is small
2. For control structures 1, 2 and 6, the best result is given if we control the temperature in the top tray manipulating the reboiler duty
3. For control structure 3, the best result is given if we control the temperature in tray 31 manipulating the reboiler duty
4. For control structure 4, the best result is given if we control the temperature in the top tray manipulating the distillate flow rate

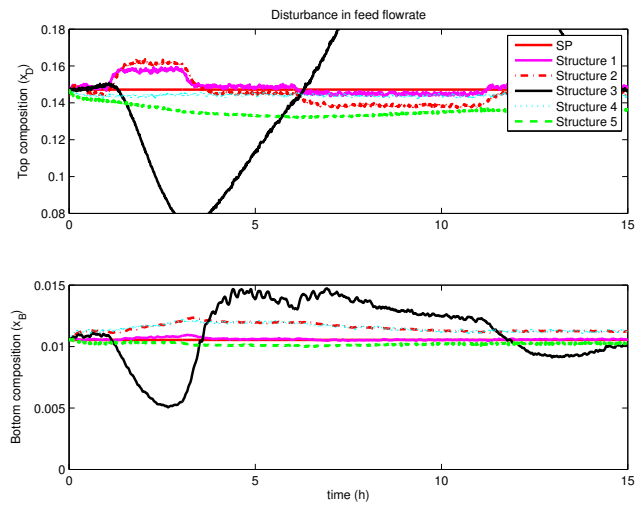

Figure 46: Ramp in feed flow rate: top and bottom compositions (including ratio to feed).

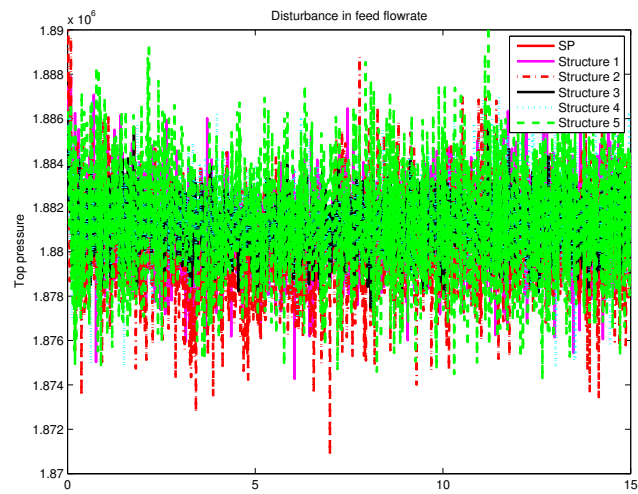

Figure 47: Ramp in feed flow rate: pressure (including ratio to feed).

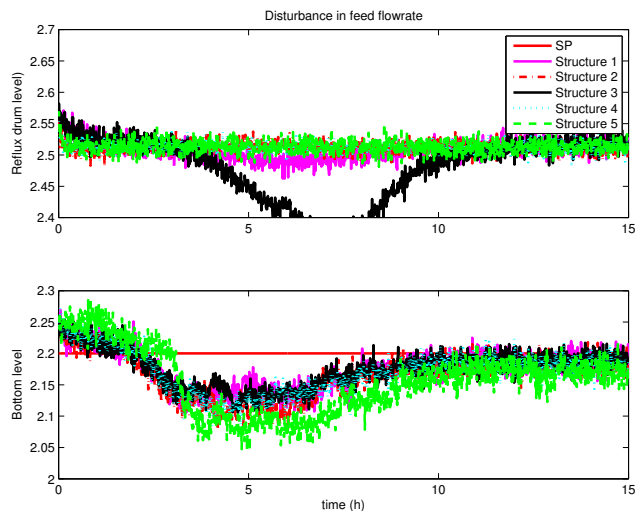

Figure 48: Ramp in feed flow rate: level (including ratio to feed).

5. For control structure 5, the best result is given with the open loop approach (no temperature control)
6. Structures 1 and 5 give the best results
7. The control of pressure and level is not a big problem for this column as soon we choose the right control structure
8. Closing the temperature loop changes completely the dynamics of the column, then is invalidates the heuristics that we shouldn't use a small flow for level or pressure control
9. The introduction of ratio to feed improves the control performance in the presence of large disturbances in the feed flow rate. So, this should be considered in this process because large changes in feed flow rate are quite common in this column
10. The control structures that gave the best results are structures 1 and 4 with ratio to feed

References

- Hori, E.S. and S. Skogestad (2007a). Maximum gain rule for selecting controlled variables. *Accepted to be presented in Dycops/2007*.
- Hori, E.S. and S. Skogestad (2007b). Selection of control structure and temperature location for two-product distillation columns. *Chem. Eng. Res. Des.* **85**(A3), 293–306.
- Luyben, W.L. (2004). Alternative control structures for distillation columns with partial condensers. *Ind. Eng. Chem. Res.* **43**, 6416–6429.
- Luyben, W.L. (2005). Effect of feed composition on the selection of control structures for high-purity binary distillation. *Ind. Eng. Chem. Res.* **44**(20), 7800–7813.

- Ralston, P.A.S., P.B. Deshpande, P. Hanik and S. Bender (1985). Indirect dual composition control of a deethanizer. *Hydrocarbon Proc.* **64**(June), 53–55.
- Skogestad, S. (1997). Dynamics and control of distillation columns: a tutorial introduction. *Chem. Eng. Res. Des.* **75**(A6), 539–562.